

IOWA STATE UNIVERSITY

ECpE Department

Distribution System Protection

Dr. Zhaoyu Wang

1113 Coover Hall, Ames, IA

wzy@iastate.edu

Distribution System Protection

Acknowledgement:

The slides are developed based in part on Electric Power and Energy Distribution Systems, Models, Methods and Applications, Subrahmanyam S. Venkata, Anil Pahwa, IEEE Press & Wiley, 2022

1. Overview and Philosophy

- Protection is one of the most complex and difficult topics in power system engineering.
- The primary philosophy of protection is to preserve sensitivity, selectivity, minimum time of operation, and reliability.
- A local protection philosophy covering about two to three buses (or nodes of all phases) beyond any protective device, but it does not cover a wider area for defense against catastrophic failures to provide higher reliability and resiliency.
- Factors to be considered: trade-off to achieve proper protection with cost-effectiveness, safety of personnel and equipment, etc.
- Distribution systems need protection against overcurrent and overvoltage. In this chapter, protection will be limited to overcurrent considerations only.
- With the introduction of computer-based protection devices, the existing protection systems are changing gradually.

2. Role of Protection Studies

- Reasons for conducting protection studies:
 - To prevent damage to equipment and circuits caused by faults or abnormal conditions.
 - To prevent hazards to the public and utility personnel.
 - Utilities depend on protection to maintain highest service reliability, safety, and resiliency by preventing unnecessary power interruptions.
- The protection system minimizes the effects of damage when an interruption occurs, and minimizes the duration of service interruptions to customers due to a fault or short circuit and the number of customers affected with proper coordination and operation of the protective devices.
- Primary objectives of performing protection studies as a part of comprehensive distribution planning and/or design studies:
 - Basic addition or expansion of a distribution system
 - Manual and automatic sectionalizing of portions of a system
 - Decision on proper phase spacing between conductors and selection of insulation
 - Vegetation management to assure the highest level of system reliability
 - Inspection for other potential problems such as salt deposition on conductors and dust accumulation on insulators
 - Preventive equipment maintenance

3. Protection of Power-carrying Devices

Adequate protection must be provided for all types of power-carrying equipment such as:

- Lines, feeders, and laterals
- Distribution substation transformers and distribution transformers
- Capacitors
- Voltage regulators
- Segments of the system itself
- Conventional and distributed energy sources (DERs)
- Loads

4. Classification of Protective and Switching Devices

- Protective devices are intentionally created weak links to safeguard expensive power-carrying assets such as lines (feeders and laterals) and transformers.
- Basic protective devices for overcurrent protection are designed to burn and open to clear overcurrent.
- Purpose of protective devices is to protect equipment from overloads and short circuits.
- Various devices are used to protect different parts of distribution systems.
- The different classification of Protective and Switching Devices is shown in the figure present in the next slide.

4. Classification of Protective and Switching Devices

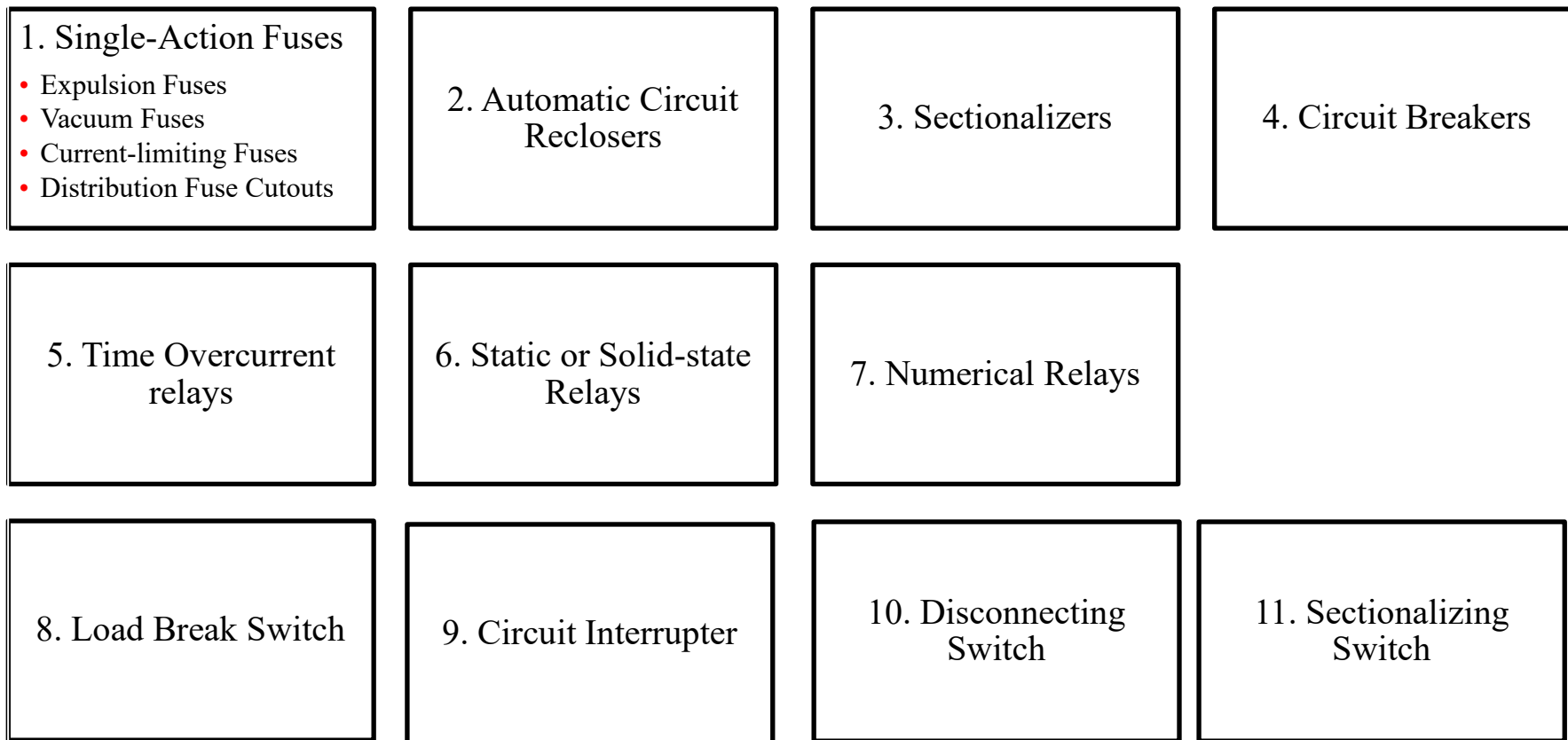

Fig: Classification of Protective and Switching Devices

4.1 Single-Action Fuses

- Fuses have a circuit-opening fusible part that is severed by current passing through it.
- Fuses can be used for sectionalizing feeder segments to create zones.
- Single-action fuses handle the expected load of distribution lines (e.g., feeders, laterals).
- Fuses perform both sensing and fault-interrupting functions.
- **Drawback:** Fuses need to be replaced after a single operation.
- While fuses are inexpensive, the labor cost of changing them is significant from an operational perspective.
- Fuses are available in variety of types:
 - a) Expulsion fuses
 - b) Vacuum fuses
 - c) Current-limiting fuses.

4.1.1 Expulsion Fuses

- The principal component of a fuse link is a fusible element, made of various materials, including silver.
- The fusible element is housed inside a fuse cutout as shown in the figure.
- Time-current characteristic is used to determine the fuse's operation time for a specific fault current.
- The fuses are available with single or dual elements.
- Dual-element fuses reduce long-time minimum melt currents without reducing short-time melt currents.

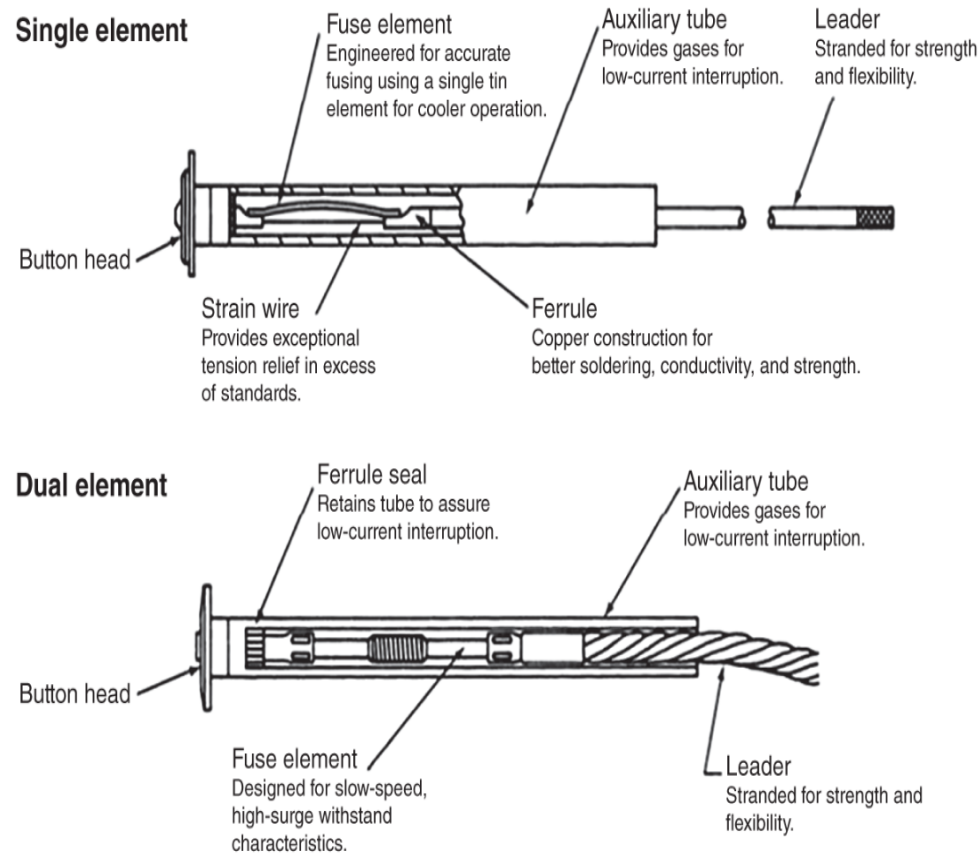

Fig: Fuse-link construction

4.1.1 Expulsion Fuses

- There are distinct types of expulsion fuses, which are designed to carry 100% of their rated current continuously.
- Operating characteristics of fuse links are distinguished by the speed of operation defined by the speed ratio as shown in the figure.
- Speed ratio of the fuse links of 100 A and below is the ratio of the current that melts the fuse link in 0.1 second to the current that melts the fuse in 300 seconds
- Speed ratio of the fuse links of rated greater than 100A, is defined as the ratio of the current that melts the fuse link in 0.1 and 600 second.

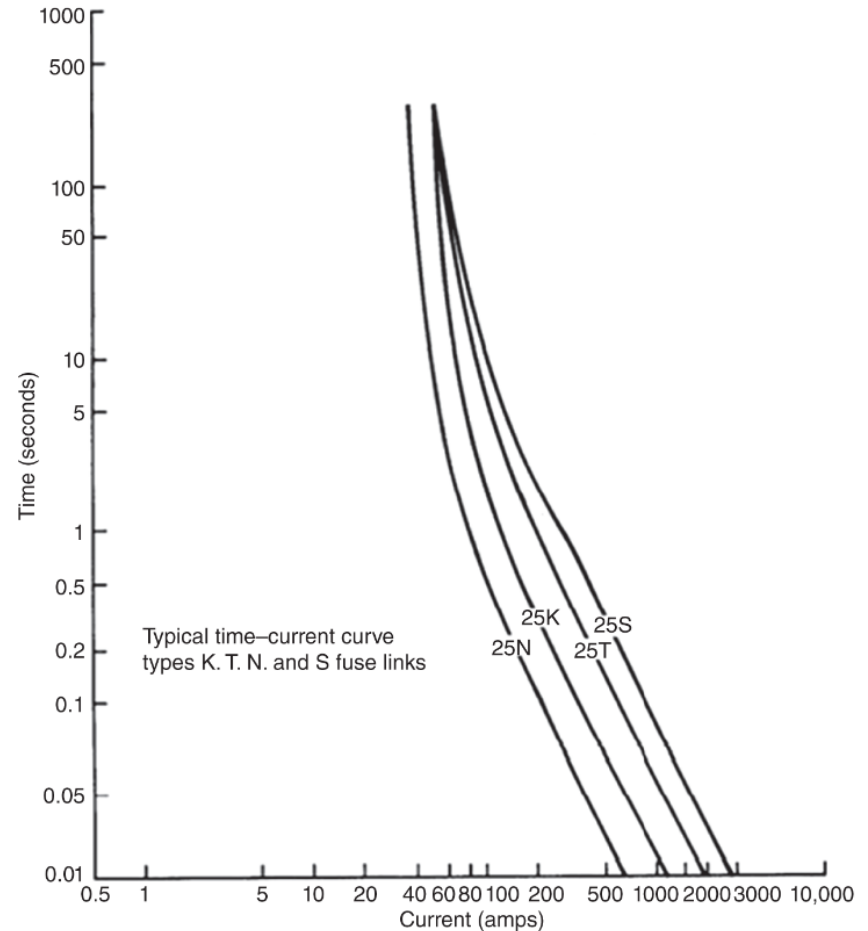

Fig: Comparison of various fuse links

4.1.1 Expulsion Fuses

- K link – “fast type” with speed ratio of 6–8.1. These are commonly used for urban systems.
- N link – This is also “fast type” with speed ratio of 6–11.
- T link – “slow type” with speed ratio of 10–13. These are suited for suburban systems.
- S link – These are “very slow” with speed ratio of 15–20.

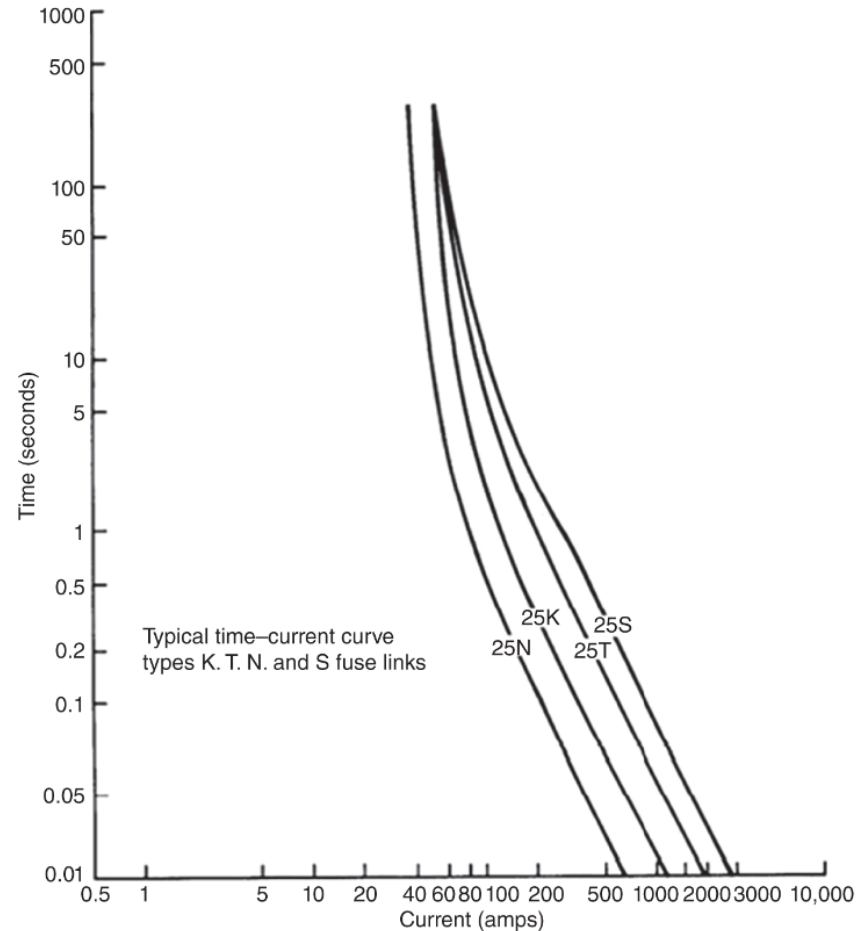

Fig: Comparison of various fuse links

4.1.2 Vacuum Fuses

- Vacuum fuses enclose the fusible element within a vacuum medium
- Internal features of vacuum fuses include arc runners, shield, and ceramic insulation
- Multiple cycles may be necessary for low fault currents to burn back the fusible element
- Vacuum fuses can be used indoors and under oil environments

4.1.3 Current-limiting Fuses

- Non-expulsion fuses limit energy to the protective device, reducing the risk of catastrophic failure to the protection device.
- Their operation depends on the type of medium in which they operate.
- High-current clearing is similar to other fuses.
- Key factors determining their operation are let-through current, melt I^2t , let-through I^2t , and peak-arc voltage.
- Basic Types of Current-limiting Fuses:
 - a) Backup or Partial-range Fuse
 - b) General-purpose Current-limiting Fuse
 - c) Full-range Current-limiting Fuse

4.1.3 Current-limiting Fuses

a) Backup or Partial-range Fuse:

- It must be used in conjunction with an expulsion fuse or some other device. It is capable of properly interrupting current only above a specified level.

b) General-purpose Current-limiting Fuse:

- It is designed to interrupt all fault currents from its rated interrupting current down to the current that causes element melting in one hour.

c) Full-range Current-limiting Fuse:

- It interrupts any continuous current (up to rated interrupting current) that will cause the element to melt.

4.1.4 Distribution Fuse Cutouts

- A fuse cutout is a housing for connecting fuse link.
- This arrangement assists the field crews to replace a burned fuse link with a new one.

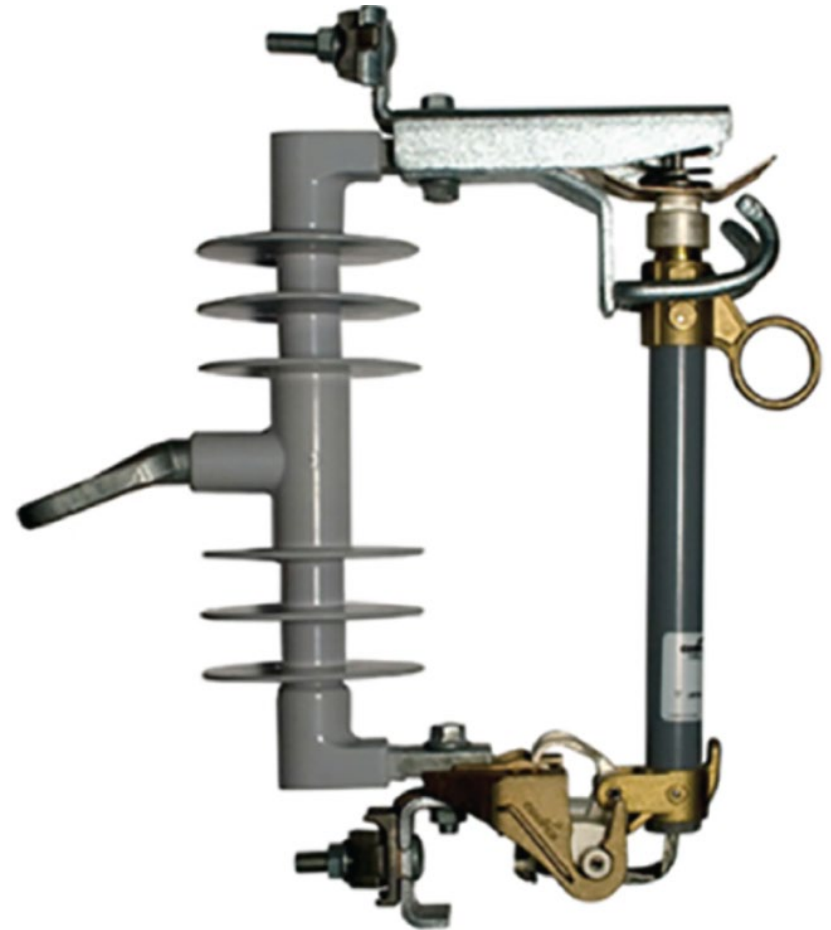

Fig: Fuse Cutout

4.2 Automatic Circuit Reclosers

- Recloser is a multifunction protective device with fault-sensing and fault-clearing capabilities.
- It is self-contained and intelligent, with the ability to sense overcurrent and interrupt the current flow, depending on the value of the current.
- Designed to automatically reclose and reenergize the line.
- Modern reclosers often feature fully capable microprocessor relays.
- Examples of modern reclosers from different manufacturers are shown in figure.
- Reclosers are lighter than circuit breakers and mounted on poles in overhead distribution systems.

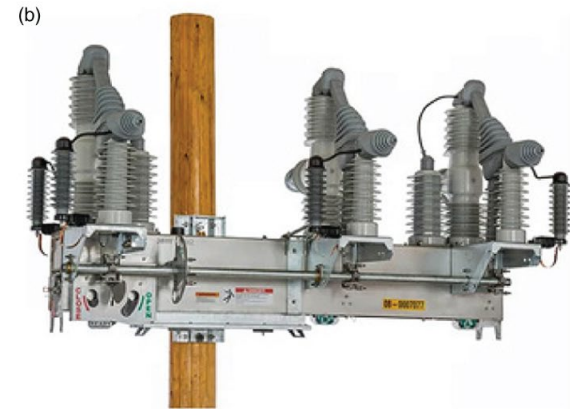
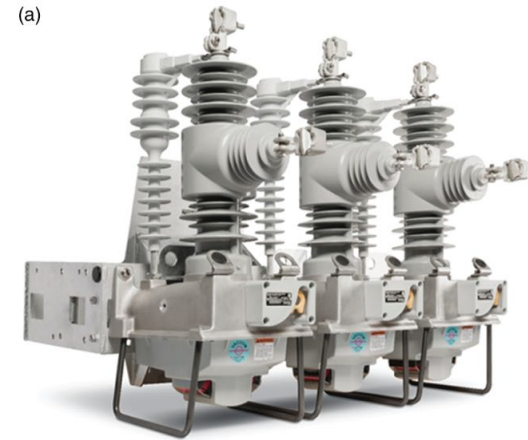

Fig: Examples of modern Recloser
(a) Nova NXT and (b) IntelliRupter PulseCloser

4.2 Automatic Circuit Reclosers

- Reclosers with advanced microprocessor protective relays are also commonly used at point of common coupling (PCC) to microgrids.
- Unlike fuse links, which interrupt either type indiscriminately, reclosers can distinguish between temporary and permanent faults.
- Figure shown depicts the time-current operating characteristics of a recloser.
- Reclosers typically have one fast (A) and one slow (C) or two slow (B and C) characteristics.

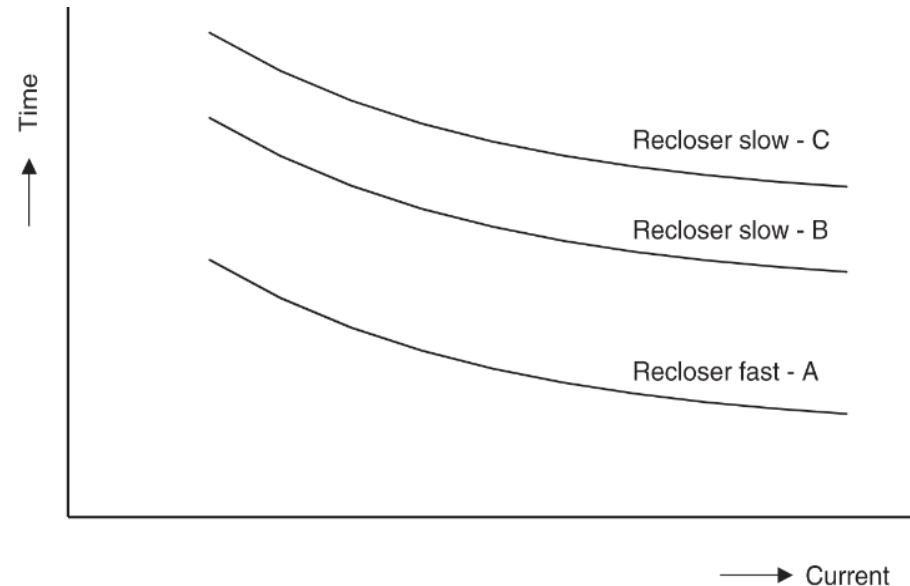

Fig: Example of recloser characteristics with one fast (A) and two slow curves (B and C)

4.2 Automatic Circuit Reclosers

- Automatic circuit reclosers trip and reclose a preset number of times to clear temporary faults or isolate permanent faults.
- Reclosers automatically reenergize the line after tripping to test for fault clearance:
 - After a fault is detected, reclosers trip and automatically reenergize to “test” the line by successive “reclose” operations while giving temporary faults repeated chances to clear or be cleared by downstream protective devices.
 - Should the fault not clear, the recloser recognizes it as a permanent fault and locks open or “locks out.”
- A drawback of many reclosers is limited fault interruption capability. Reclosers must be coordinated with upstream protective relay-controlling circuit breakers in a substation. These circuit breakers are designed for interrupting fault currents.

4.2 Automatic Circuit Reclosers

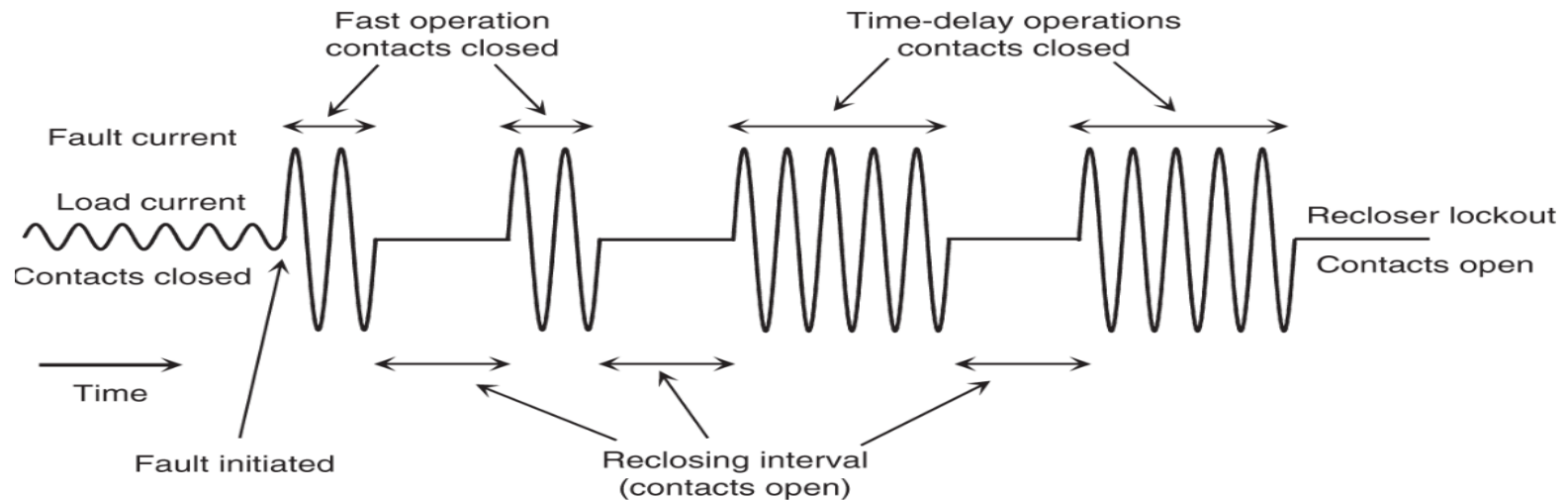

Fig: Typical recloser operating sequence to lockout

- The figure shows two fast and two slow operations of a recloser.
- Operating sequence is 2A2C if Curve C is used for slow operations.
- Operating sequence is 2A2B if Curve B is used for slow operations.
- The second two operations are intentionally slowed to allow the fault to clear if it is temporary or a downstream fuse to clear it if it is permanent.

4.2 Automatic Circuit Reclosers

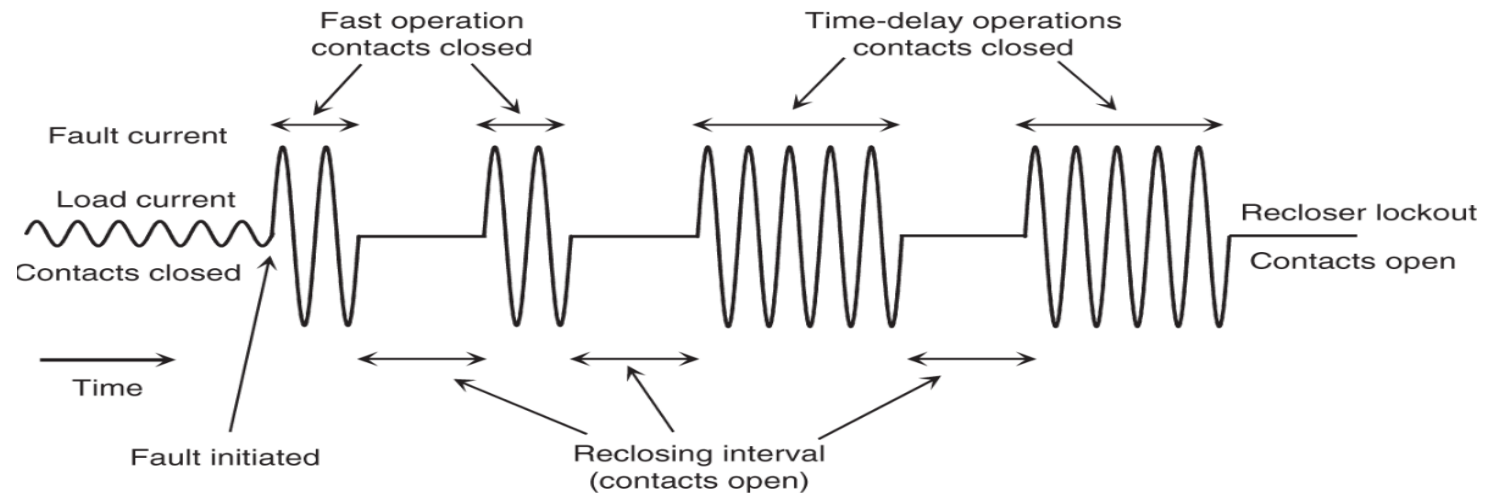

Fig: Typical recloser operating sequence to lockout

- In the given example, the recloser opened and locked out after the third reclosing action because the fault was not cleared by the downstream fuse or it was located upstream of the fuse.

4.2.1 Recloser Classifications

- Reclosers are classified as single-phase for single-phase lateral applications and three-phase for three-phase feeders.
- They can be hydraulically or electronically controlled.
- The interrupting media for reclosers can be oil or vacuum.
- Modern reclosers are typically electronically controlled.
- Most reclosers use oil-filled chambers to interrupt fault current, but recent designs incorporate vacuum circuit interruption.

4.3 Sectionalizers

- Sectionalizers are circuit-interrupting devices similar to reclosers but can be less expensive if they do not have fault-interrupting mechanisms.
- While the legacy sectionalizers did not have fault-interrupting capability, most of the modern sectionalizers are reclosers programmed to operate as sectionalizers.
- A sectionalizer applied in conjunction with a recloser or circuit breaker has the memory of counting the number of operations of the upstream device, but it does not have any fault-interrupting capability of its own.
- It counts the number of operations of the backup device (recloser or circuit breaker) during fault conditions, and after a preselected number of current-interrupting operations (reclose attempts), the sectionalizer opens and isolates the faulted section of line.

4.3 Sectionalizers

- If the fault is temporary, both the sectionalizer and the recloser reset to the normal state.
- If the fault is persistent, however, the recloser operates on its sequence, but the sectionalizer isolates the fault before the recloser starts its final reclose operation; thus, recloser lockout is avoided, and only that portion of the circuit beyond the sectionalizer is interrupted.
- The figure illustrates the operating sequence of a sectionalizer set for three counts working with a four-sequence operation of a recloser on the upstream side.

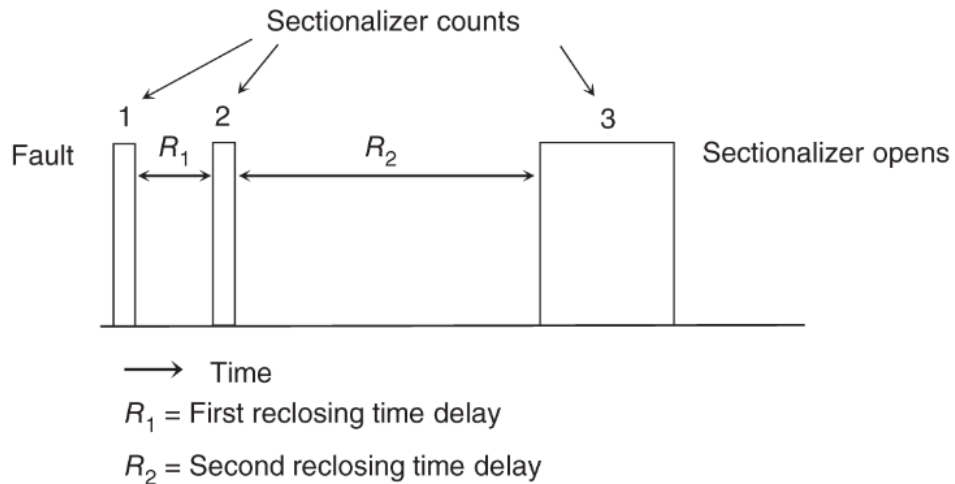

Fig: Operational sequence of a sectionalizer

4.3 Sectionalizers

- Sectionalizers can be used between two protective devices with operating curves that are close together.
- Sectionalizers can also be used on close-in taps where high fault magnitude prevents coordination of fuses with the backup recloser or breaker.
- Sectionalizers are also ideal at locations where temporary faults could frequently occur.
- They are designed to automatically reset with the mechanism provided in them.

4.4 Circuit Breakers

- Circuit breakers are commonly employed at the substation level for overcurrent protection of the feeders connected to them.
- They are mechanical switching devices capable of making, carrying, and breaking currents under short-circuit or normal operating conditions.
- Circuit breakers are expensive and bulky protective device which can only be cost justified at the substation level.
- Circuit breakers are classified by the interrupting medium and the method of storing energy:
 - Oil interruption
 - Vacuum interruption
 - Air-blast interruption
 - SF6 (gas) interruption
 - Air-magnetic interruption
- Within the distribution systems, feeder breakers normally utilize oil, vacuum, or air magnetic as the interrupting medium and energy storage.

4.4 Circuit Breakers

- Generally, relay-controlled circuit breakers are preferred to reclosers due to their better accuracy. Thus, opening and closing of substation circuit breakers are always controlled by protective relays.
- An automatic circuit breaker is equipped with a trip coil connected to a relay or other means, designated to open the breaker automatically under abnormal conditions, such as fault and overcurrent.
- It is frequently used to restore service quickly after a line trips out owing to lightning or a temporary fault. The stored-energy mechanisms in a circuit breaker are designed to close its contacts several times.
- These operations use:
 - (i) motor-compressed spring for one closing/opening operation with spring reset within 10 seconds,
 - (ii) compressed air or other gas for two closing/opening operations,
 - (iii) pneumatic or hydraulic breakersfor higher numbers such as five closing/opening operations.

4.5 Time Overcurrent Relays

- Classical electromechanical protective relays have been in use since the early days of electricity, dating back to the 1880s.
- Electromechanical relays are still widely used globally and will continue to be utilized in the foreseeable future.
- Electromechanical relays are reliable, but unable to perform complex or adaptive protection and cannot advise operations about their own failure.

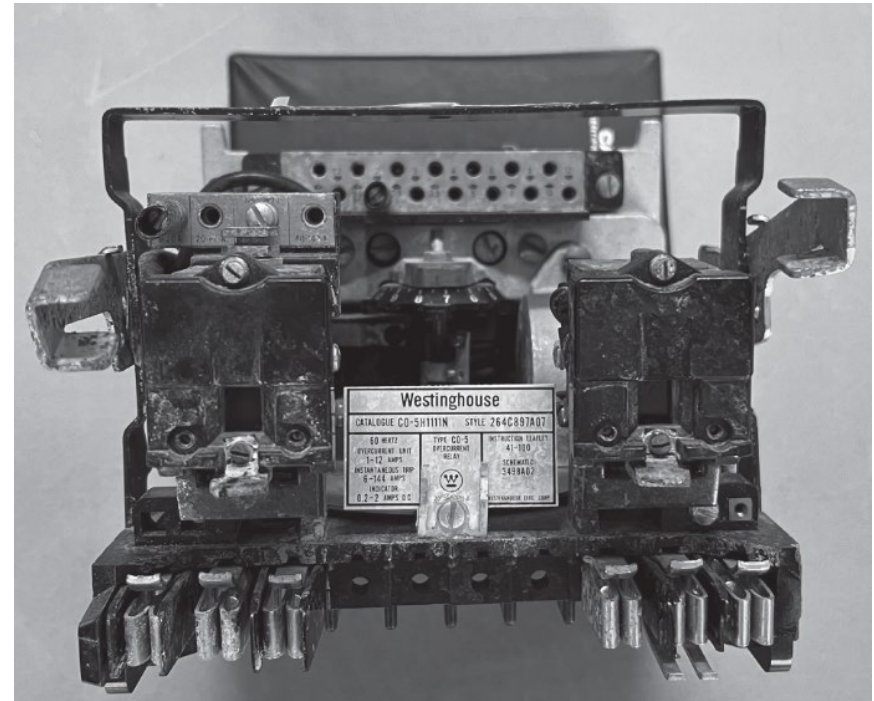

Fig: Electromechanical Overcurrent Relay

4.5 Time Overcurrent Relays

- Relays have the intelligence to detect an abnormal condition and send proper signals to circuit breakers to achieve automatic tripping and closing of the circuit breaker contacts.
- For primary distribution systems, sensing function requires instrument transformers to step down both voltages and currents to standard 120 V and 5 A.
- For example, for a 10-MVA, 115-kV/12.47-kV three-phase substation transformer, a voltage transformer (VT) with turns ratio of 60 : 1 will be required to step down 7.2 kV (L–N voltage on the low-voltage side) to 120 V. Similarly, a current transformer (CT) with turns ratio of 500 : 5 will be needed to step down the full load current of 463 to a lower value suitable for relays.
- The time-inverse overcurrent relay is the most used relay for overcurrent protection. This relay has plugs to select tap setting (TS), which is the minimum current at which the relay starts operating. Typical TSs range from 1 to 12 A.

4.5 Time Overcurrent Relays

- The other setting on these relays is the time dial (TD) setting, which delays the operation of the relay, with values ranging from 0.5 to 11.
- The figure illustrates the characteristics of a commonly used time-inverse overcurrent relay (CO-8), with the x-axis representing multiples of tap value current or multiples of tap setting (MTS).
- MTS is obtained by dividing the current flowing in the relay by selected TS.

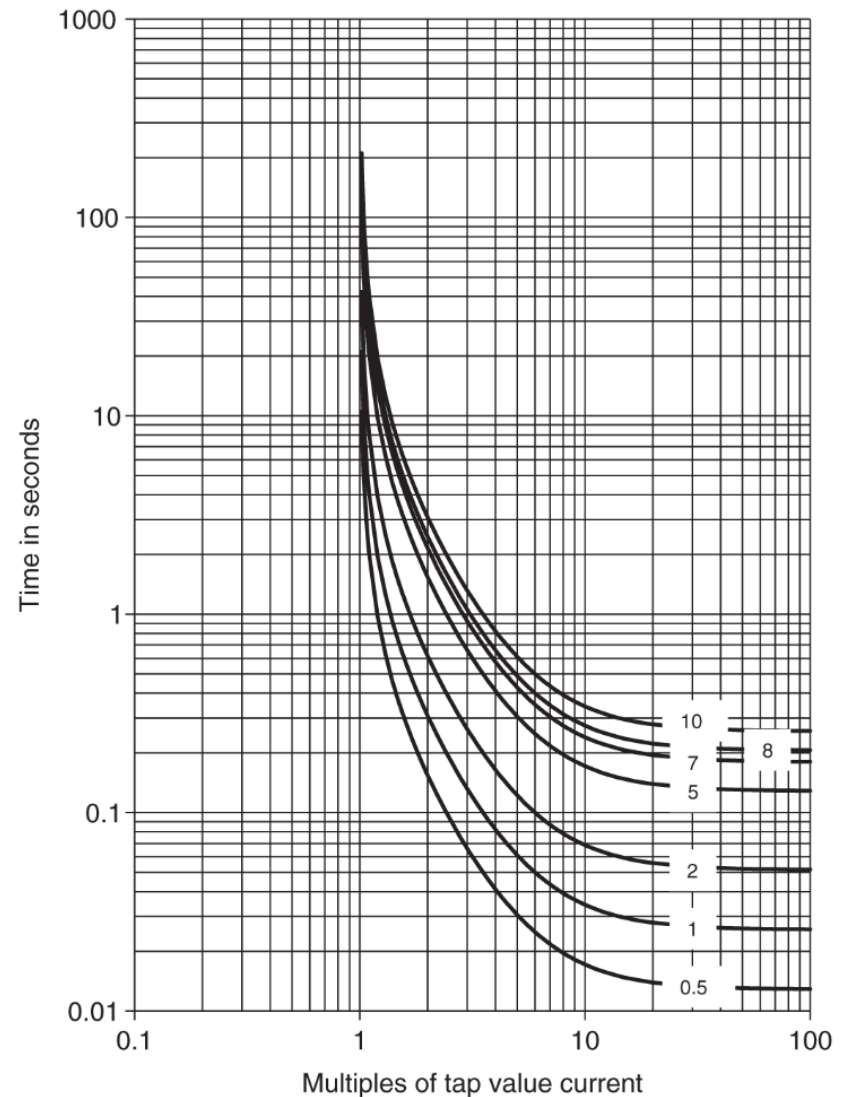

Fig: Time–current characteristics of CO-8 time-inverse overcurrent relay at different time dial values.

4.5 Time Overcurrent Relays

- To understand the use of the figure, consider a fault current of 960 A for CT of 300 : 5 and TS of 4 A for the relay.
- The current seen by the relay can be obtained by dividing the fault current by the CT ratio,

$$I_{\text{relay}} = 960 \times 5/300 = 16 \text{ A}$$

- Now, we divide the relay current by TS to get MTS,

$$\text{MTS} = I_{\text{relay}} / \text{TS} = 16/4 = 4$$

- To understand the use of the figure, consider a fault current of 960 A for CT of 300 : 5 and TS of 4 A for the relay.
- The current seen by the relay can be obtained by dividing the fault current by the CT ratio,

$$I_{\text{relay}} = 960 \times 5/300 = 16 \text{ A}$$

- Now, we divide the relay current by TS to get MTS,

$$\text{MTS} = I_{\text{relay}} / \text{TS} = 16/4 = 4$$

Fig: Time–current characteristics of CO-8 time-inverse overcurrent relay at different time dial values.

4.5 Time Overcurrent Relays

- If we consider that a TD of 5 is selected, the operating time of the relay under these conditions by noting the time on the graph with TD = 5 at MTS of 4, which is about 0.4 second.
- Although the present generation of overcurrent relays use digital technology to process the input current, these relays continue to mimic the time-inverse overcurrent characteristics provided by the classical electromechanical relays.
- The standard characteristics of relays used in the United States are given by an equation in terms of TD and MTS:

$$t = \frac{TD}{7} \left[\frac{\beta}{(MTS)^\alpha - 1} + K \right]$$

where t is the operating time of the relay, and α, β , and K are constants.

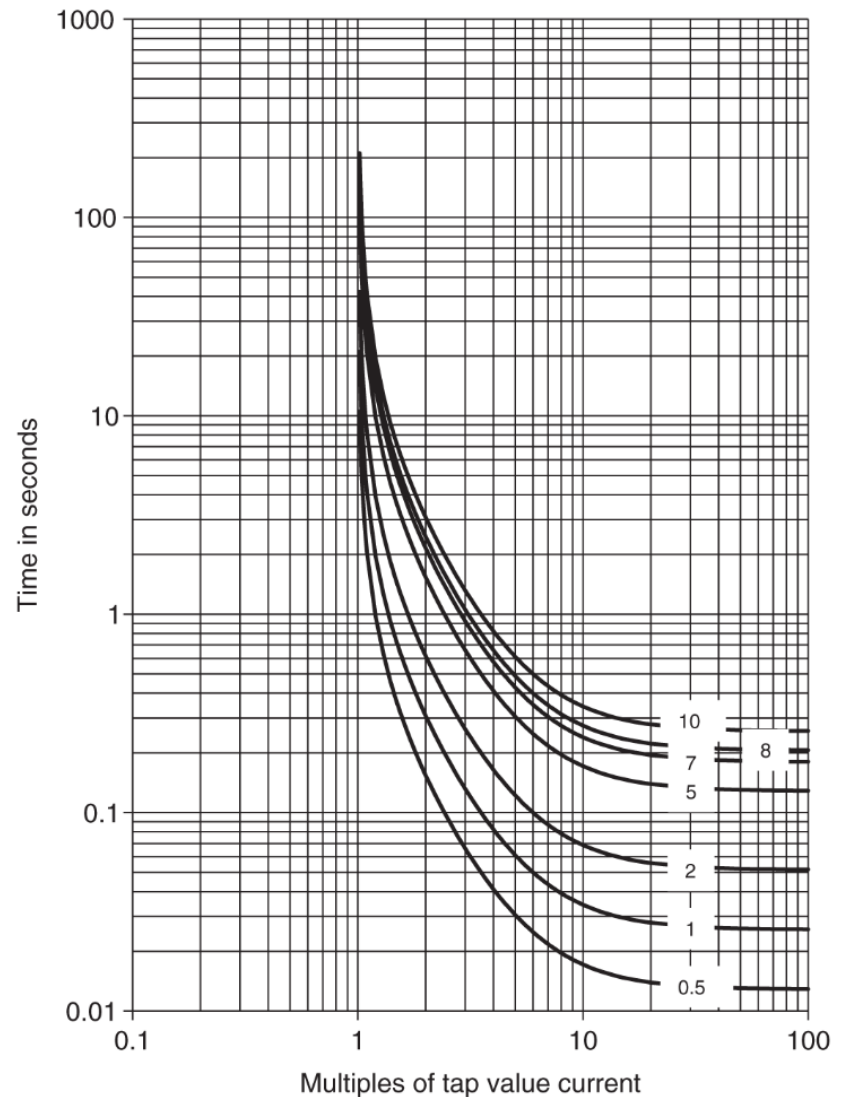

Fig: Time–current characteristics of CO-8 time-inverse overcurrent relay at different time dial values.

4.5 Time Overcurrent Relays

- The values of α , β , and K depends on the relay types and are illustrated in the following table.
- The corresponding graph of different types of relay is illustrated in the figure.

| Characteristics | α | β | K |
|-------------------------|----------|---------|---------|
| IEEE extremely inverse | 2 | 28.2 | 0.1217 |
| IEEE very inverse | 2 | 19.61 | 0.491 |
| CO8 inverse | 2 | 5.95 | 0.18 |
| IEEE moderately inverse | 0.02 | 0.0515 | 0.114 |
| CO2 short time inverse | 0.02 | 0.02394 | 0.01694 |

Table: Constants for different time-inverse overcurrent relays.

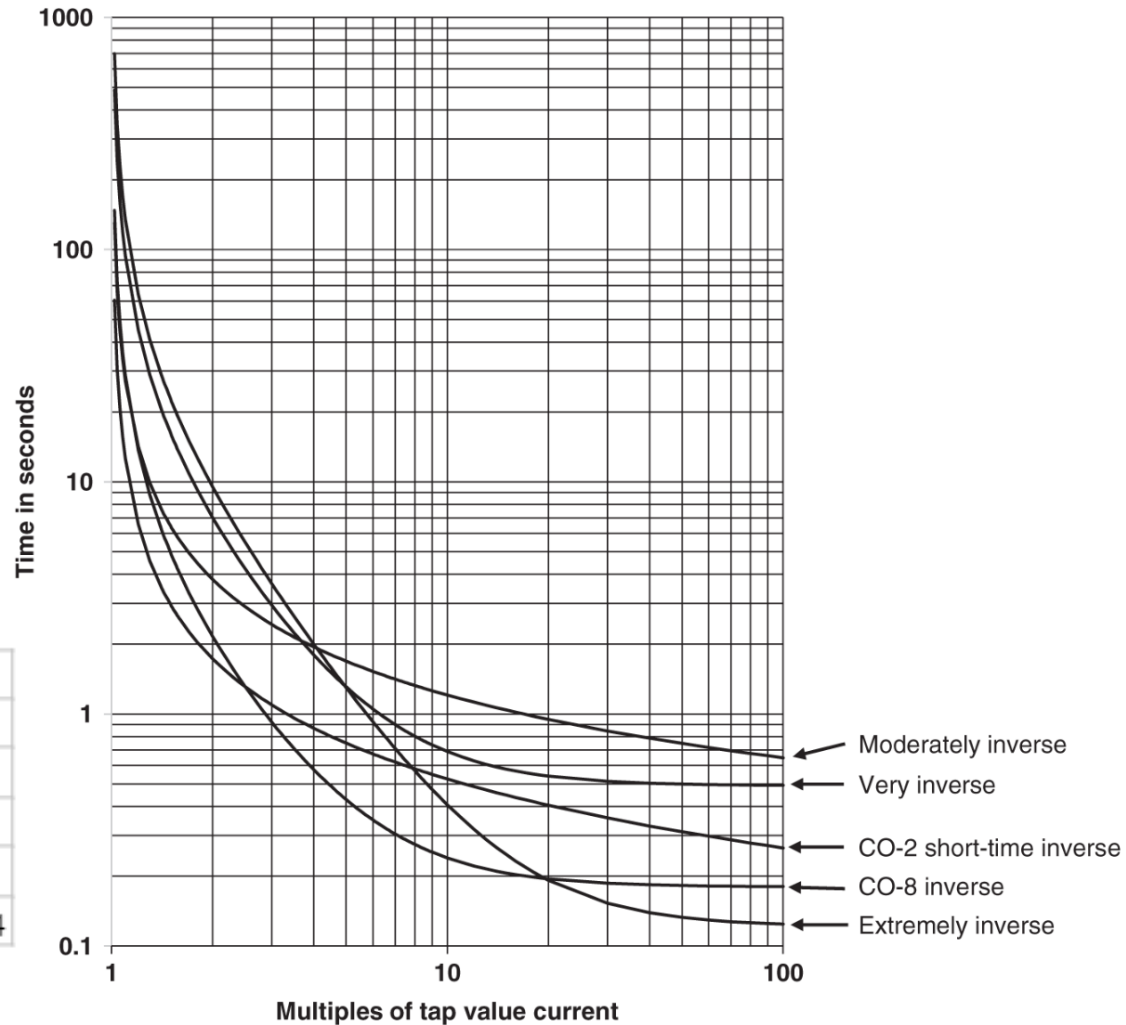

Fig: Time–current characteristics of different time-inverse overcurrent relays at time dial of 7.

4.6 Static or Solid-state Relays

- Static relays do not have moving parts, unlike electromechanical relays.
- The invention of transistors enabled the development of static relays.
- Static relays are more accurate and have faster response times compared to electromechanical relays.
- These relays require high-quality DC power supplies, which are not so practical in substation environments.
- Solid-state or static relays emerged in the early 1960s but had low reliability, leading to their short lifespan.

4.7 Digital or Numerical Relays

- Digital or numeric relays emerged in the mid-1980s with the availability of low-cost microprocessors.
- They have become the preferred choice due to their multifunction capabilities and high accuracy.
- Modern digital relays are commonly used for overcurrent protection in distribution system feeders.
- Digital relays offer increased reliability and are now preferred for circuit protection ranging from 480 V to 765 kV.
- They perform complex protection and control functions, possess self-diagnosis capabilities, and can notify operators of failures.

4.7 Digital or Numerical Relays



- Digital relays are widely used as both protective relays and microgrid controllers.
- They have introduced new functions such as breaker failure detection, digital communications, adaptive protection, subcycle fast protection, and harmonic restraints.
- These multifunction devices have significantly advanced parts, reduced costs, and simplified maintenance in substations.
- Digital relays have improved data collection for continuous monitoring and event root cause analysis.

4.8 Load Break Switch

- Load break switches are circuit disconnect devices used to make or break a circuit at specified currents.
- They are equipped with auxiliary equipment to enhance the speed of the disconnect switch blade.
- The auxiliary equipment also helps modify the arcing phenomenon to ensure safe interruption of the circuit.
- Load break switches are designed to handle the switching of loads, providing a reliable means of isolation and control.

4.9 Circuit Interrupter

- Device designed to open and close a circuit by nonautomatic means and to open the circuit automatically at a predetermined overcurrent value without damage to the device when operated within its rating.

4.10 Disconnecting Switch

- Mechanical device with movable member.
- Connects or disconnects contact members.
- Typically operated on dead circuits (non-energized circuits).
- Sometimes operated on energized low-capacity circuits.
- Arc extinguishes by itself on low-capacity circuits.
- Commonly used for earliest low-voltage circuits.
- Arc burns while opening switch at higher currents and voltages.
- Arc damages or destroys the contacts.

4.11 Sectionalizing Switch

- Sectionalizing switch allows breaking the feeder into multiple sections.
- It does not have any other function besides sectionalizing.
- Disconnecting switch and load break switch can be sectionalizing switches.
- Sectionalizers and reclosers are not sectionalizing switches.

4.12 Example Distribution Systems

- Several sectionalizing switches are deployed
- The solid circles are used for sectionalizing switches on the feeders (normally closed).
- Open circles are used for end-of-the-feeder tie switches (normally open).

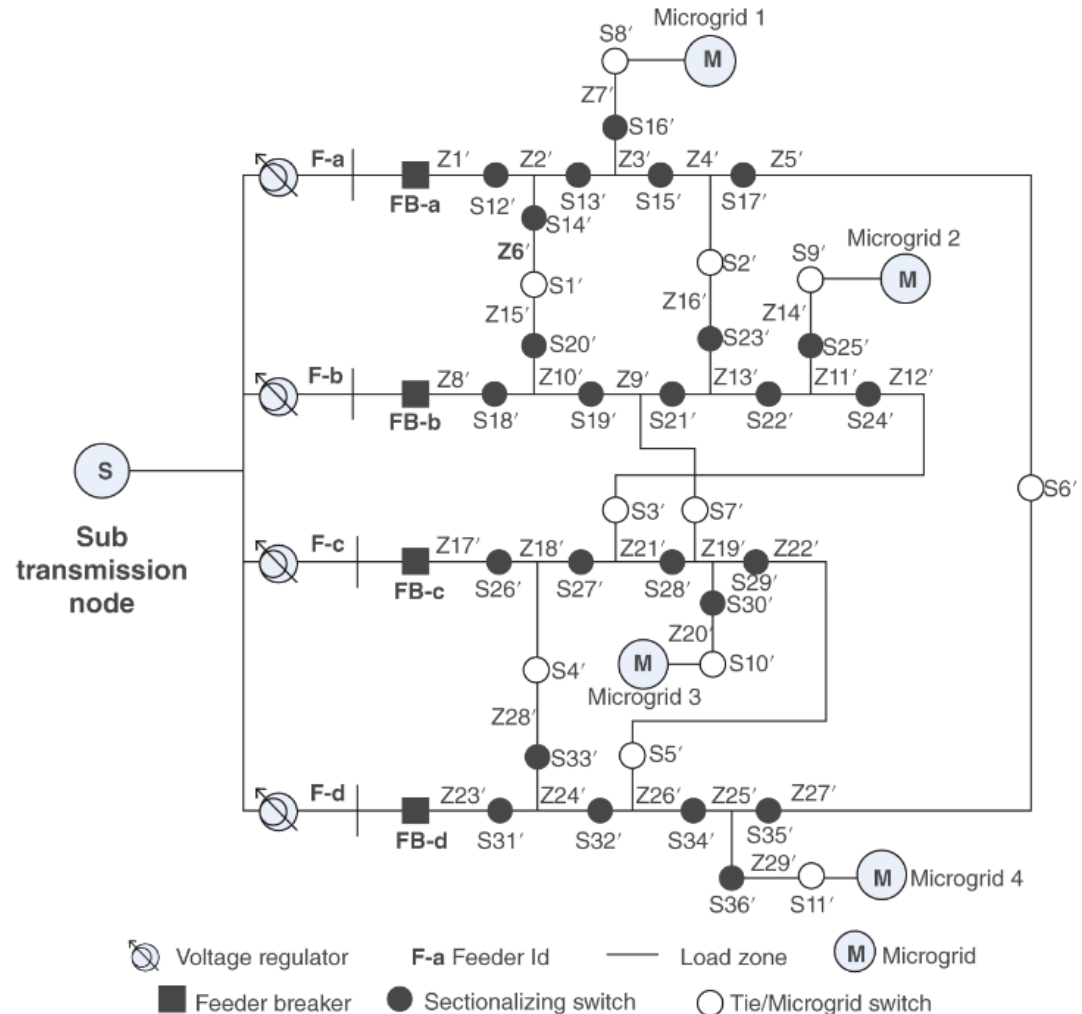

Fig: A typical distribution system depicting various components including tie and sectionalizing switches

5 New Generation of Devices

5.1 Smart Switching Devices

- Recent advances in technology have resulted in a new class of smart switching devices.
- The concept of these devices is still in several stages of development. A lot more research needs to be done before one could realize an automated fuse or a similar device.
- A brief description of some of these devices under development follows.

5.1.1 Smart Fuses

- A smart fuse device is a combination of a conventional fuse with intelligent sensor that simulates conventional current-limiting characteristics during high current faults and has the inherent ability to self-monitor and the capability to be triggered from an external source.
- The fuse needs to be replaced manually after it melts when it blows following a fault.
- The smart fuse can be used for both substation transformer and secondary conductor overcurrent protection.
- The device allows the medium voltage system to be grounded with a low resistance to minimize ground fault currents while still allowing coordination between upstream and downstream devices.
- It provides protection against single phasing without sacrificing the current-limiting features.

5.1.2 Smart Reclosers (Interrupters)

- A smart recloser is a combination of a recloser with some form of intelligence and control incorporated to achieve automation.
- This Wi-Fi-enabled electrical equipment is a kind of “smart switch” that utilities use to more quickly detect and correct outages along their distribution systems.

5.1.3 Smart Circuit Breakers

- Most of the AC circuit breakers deployed in the field are simple, electromechanical devices that sit idle most of the time.
- But the latest versions are coming with features such as wireless connectivity and computing power that are meant to turn them into something more like a smart meter or a smartphone.

6. Basic Rules of Classical Distribution Protection

- For a fault anywhere on the system where momentary outages are acceptable, it must be given a chance to be temporary by providing a reclosing operation.
- In responding to faults found to be permanent after the designated number of reclosing operations have been performed, the protection devices must remove from service only the smallest possible portion of the system necessary for isolation of the faulted segment.
- This assures that minimum number of customers are affected and thus assures higher reliability for the system under study.
- By conventional definition, when two or more protective devices are applied to a system, the device nearest to the fault on the supply side is the “primary” device. The other ones toward the upstream are called the “backup” devices, as shown in the Figure.

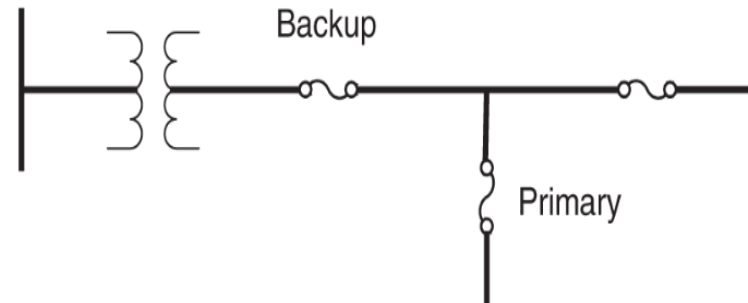

Fig: Operational convention for protective device

6. Basic Rules of Classical Distribution Protection

- To minimize the effects of faults on the main feeder, sectionalizing devices can be used to divide the feeder into smaller segments using devices such as reclosers, sectionalizers, and/or a combination of both.
- All taps branching off the feeder should have a protective device where it connects to the main feeder:
 - Fuses are normally used for taps serving single-phase loads for short distances (less than a mile).
 - Reclosers and sectionalizers are utilized for large taps serving larger loads for longer distances.
- The fast-trip curve of the recloser is used to clear temporary faults on the main feeder and taps. For permanent faults on taps, the recloser time-delay curve allows the tap fuse to clear, resulting in an outage on the tap only.
- Reclosers reduce the operation of fuses for temporary faults, but they can cause momentary interruptions on main feeders, which can be detrimental to certain loads.
- Momentary interruptions can be reduced by midpoint sectionalizing devices. Critical industrial or commercial loads can be protected by installing a recloser on the main feeder just downstream from the point of coupling of the critical load.
- Reclosers can also be added to longer taps off the main feeders to relieve momentary interruptions caused by faults on the tap.

7. Coordination of Protection Devices

- Distribution protection coordination is a complex process with multiple variables and valid solutions.
- The art of protection plays a crucial role in achieving effective coordination.
- Coordination is particularly relevant for traditional distribution systems with radial topology and one-way power flow.
- Proper coordination of protective devices offers benefits such as eliminating service interruptions from temporary faults, minimizing the impact on customers, and optimizing service restoration.

7. Coordination of Protection Devices

- To conduct proper coordination, the following data are required:
 - a) Feeder configuration diagram.
 - b) Location of protective devices.
 - c) Mathematical models of protective devices, including their time-current characteristics.
 - d) Expected range of normal load currents at all locations within the system.
 - e) Expected range of fault currents at all locations within the system.

7.1 General Coordination Rule

- Classical coordination of two local devices is achieved by utilizing time-current coordination characteristics, which serve as models for the devices.
- The coordination process involves sequentially coordinating adjacent devices from the load side to the source side for all device pairs and feeder segments in the system.
- The objective is to maintain a minimum coordination time interval between the primary device near the fault location and the immediate backup device(s), considering the system's topology.
- This coordination procedure must be repeated for all device pairs within the system.
- The coordination results are subjective due to the nature of protection, allowing for multiple viable solutions for a specific fault scenario.

7.2 Fuse – Fuse Coordination

7.2.1 Model for Fuses

- Fuse is an overcurrent device with a circuit-opening fusible member, which is directly heated and destroyed by the passage of overcurrent in the event of an overload or short circuit. Thus, the time needed to melt the fuse link decreases with increase in current.
- The inverse-time melting characteristics of a fuse link are represented by the minimum-melting curve (MMC) and the total clearing curve (TCC).
- The difference in two curves is the arcing time within the fuse.

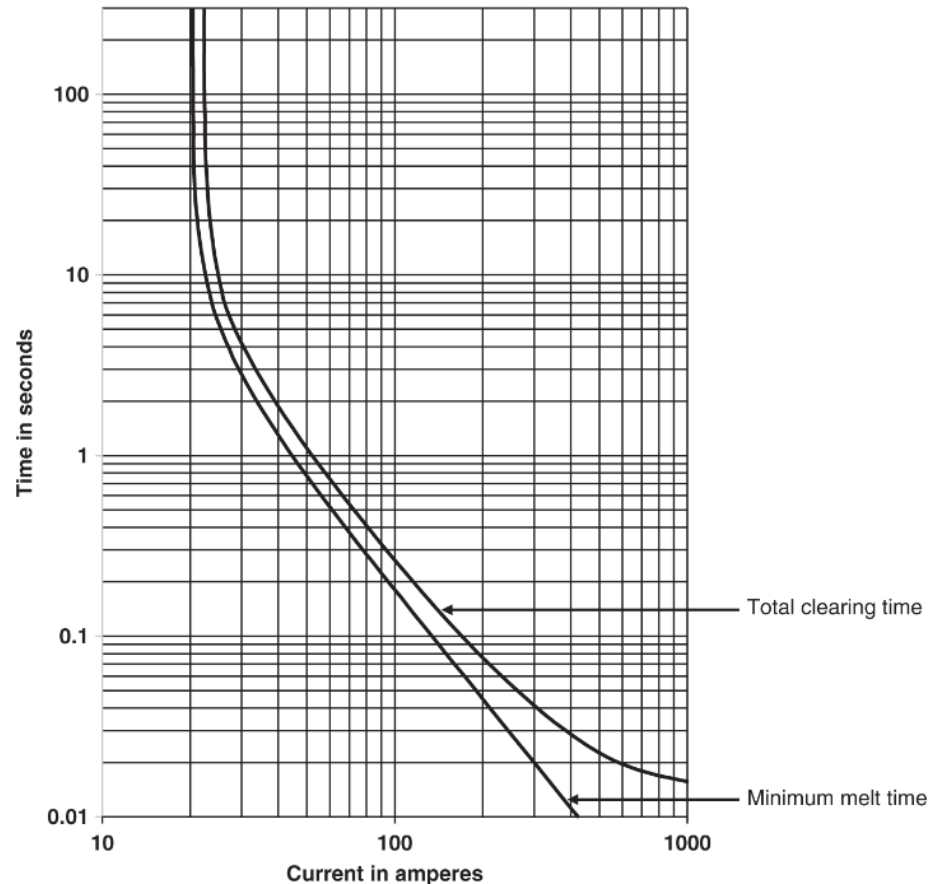

Fig: Time-current model of 10K fuse link

7.2 Fuse – Fuse Coordination

7.2.1 Model for Fuses

- Typically, a new fuse will follow these curves. However, over time with multiple overloading situations, the melting time will decrease.
- The damaging time curve is approximately 75% of the MMC. The 25% margin considers some operating variables such as ambient temperature and loading.
- The 25% margin provides a subjective allowance for factors like climate and operating conditions at the specific location.
- This margin is subjective in nature, and different values can be used, depending on the climate and operating conditions at the specific location.
- Note that the 10K fuse link starts to melt at 20 A, which is twice the rating of the fuse. As a general rule, fuse link rating must be greater than the full load value divided by 1.5. Therefore, 10K fuse link will be appropriate for full load less than 15 A.
- General equations to model different fuse links are not available. Most often, fuse link characteristics are digitized for use in computer-based coordination software.

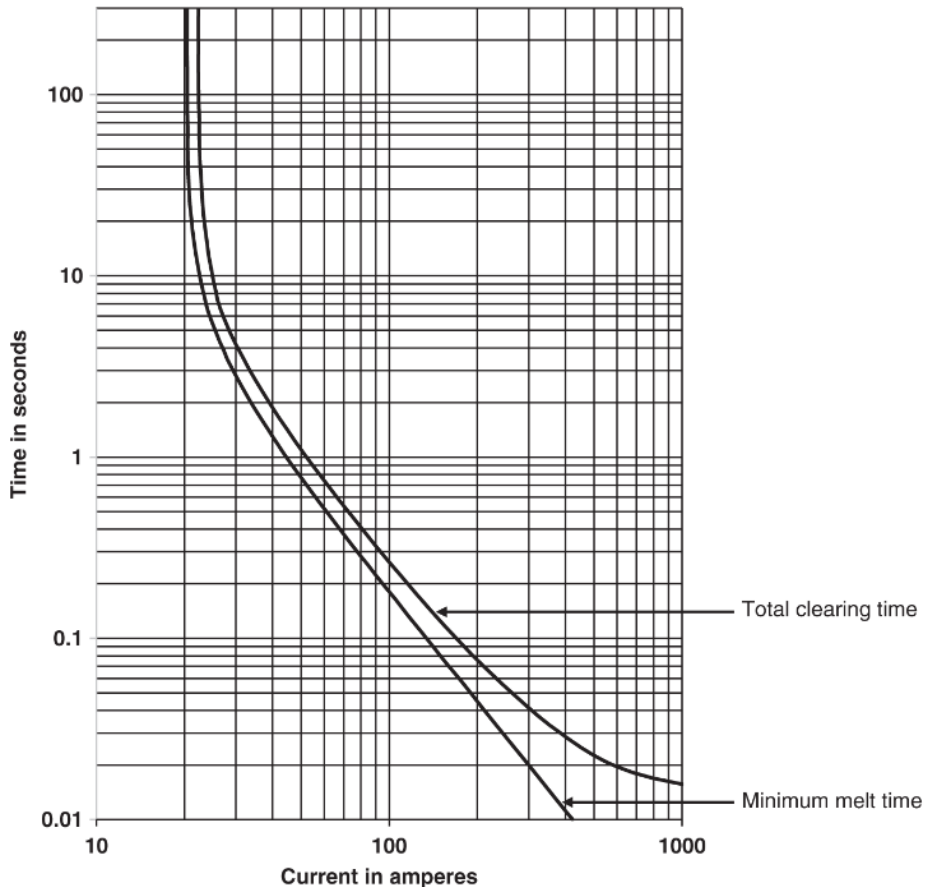

Fig: Time-current model of 10K fuse link

7.2.2 Rule for Fuse–Fuse Coordination

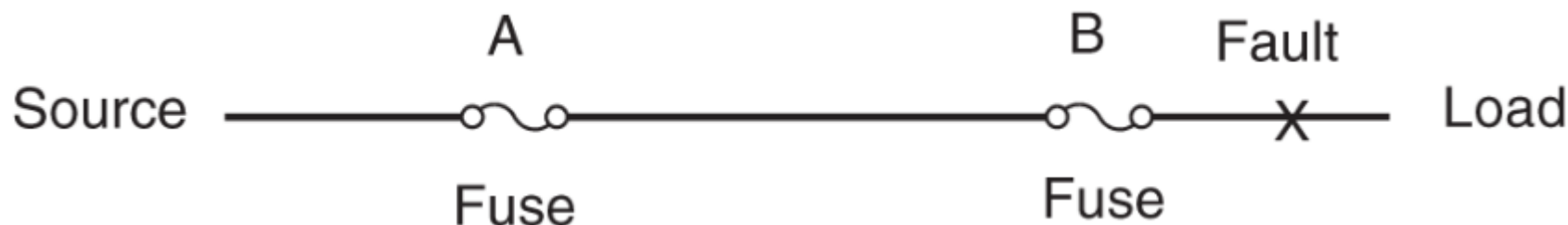

Fig: Fuse – Fuse Coordination of a simple radial system

- Figure shows a simple radial feeder. For the fault at the location shown in the figure, to coordinate fuse links A and B successfully, the **total clearing time curve of B** must be **lower** than the **damaging time curve of fuse A** within the desirable coordination current range.
- According to the damaging curve, as the name implies, the fuse deteriorates whenever the current reaches or exceeds the corresponding value. A generally acceptable method is that the total clearing time of B should not exceed 75% of the minimum melt time (MMT) of A. This coordination procedure can be further illustrated with the example provided in the next slide.

7.2.2 Rule for Fuse–Fuse Coordination

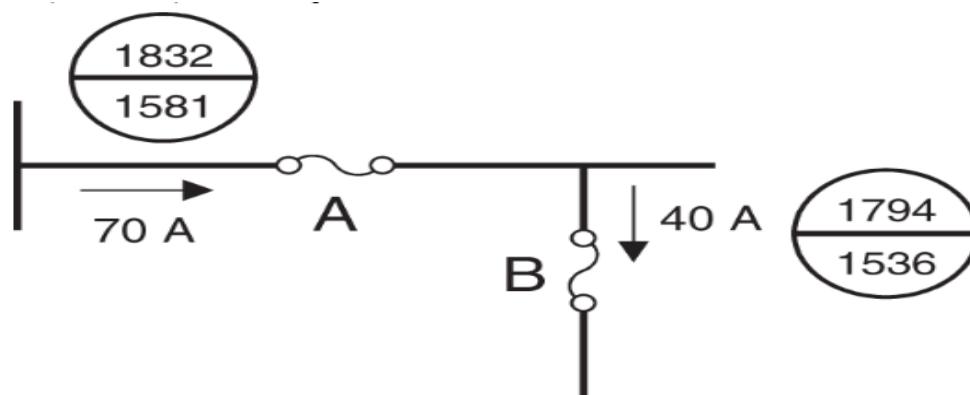

Fig: Part of a distribution system protected by fuse links.

- Figure shows part of a 12.47-kV distribution system with maximum fault, minimum fault, and full load current at the respective fuse link locations. We select fuse links Type T for locations A and B to achieve proper protection with coordination between the two fuse links.
- As the first step, we select the fuse links based on the specified full load. For location B, the fuse link must have rating higher than $40/1.5 = 26.66$ A, and for location A, it must have a rating higher than $70/1.5 = 46.66$ A. A 30T fuse link for location B and a 50T for location A will work. However, we have to make sure that they follow the coordination rules.

7.2.2 Rule for Fuse–Fuse Coordination

- Figure on the right shows the MMC and TCC of the two selected fuse links. The critical current for coordination is 1794 A, which is the maximum fault current seen by both fuse links.
- The total clearing time of 30T is 0.037 seconds, and the MMT of 50T is 0.05 seconds at this current. The ratio of these two times is $0.037/0.05 = 0.74$, which is acceptable because this ratio must be lower than 0.75.

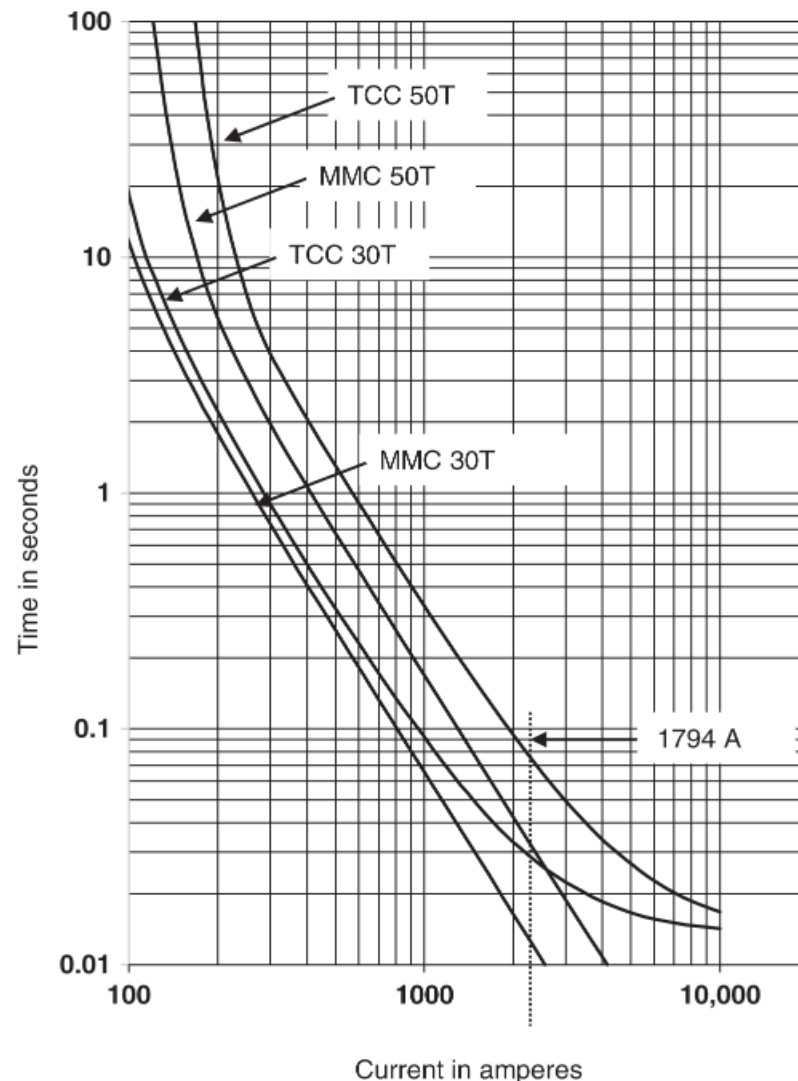

Fig: MMC and TCC curves of 30T and 50T fuse links and their coordination at the maximum fault of 1794 A.

7.3 Recloser – Fuse Coordination

- Fig. a shows a typical model for a recloser, which is time versus current curve.
- It has a fast curve A and time delay curve C. The curve in the middle is that of the downstream fuse link, shown in Fig. b.
- The fuse link curve intersects the slow and fast curves of the recloser at “a” and “b,” which give the minimum fault current and the maximum fault current for which coordination between the recloser and the downstream fuse is required.
- The coordination should ensure that for permanent faults in downstream of the fuse, the fuse should clear the fault.

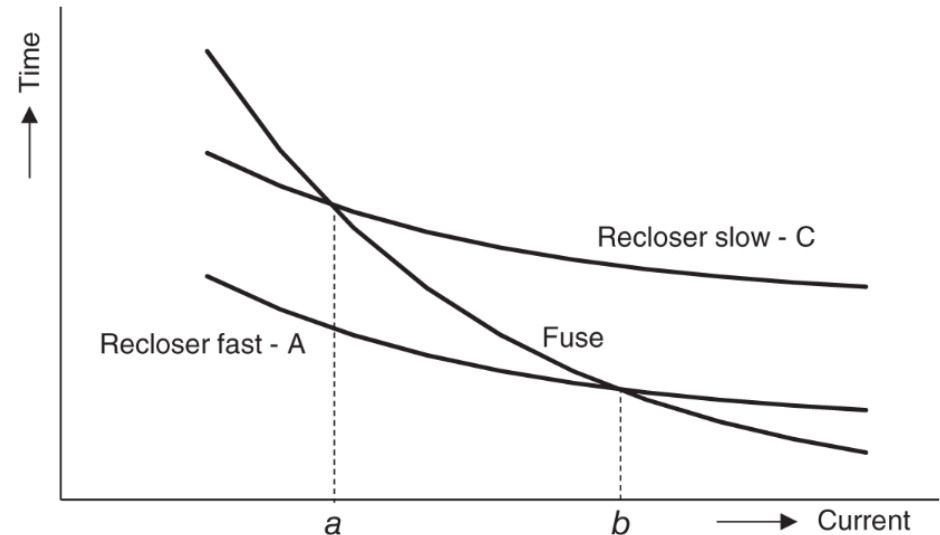

Fig. a: Time–current characteristic curve for a recloser and a downstream fuse link

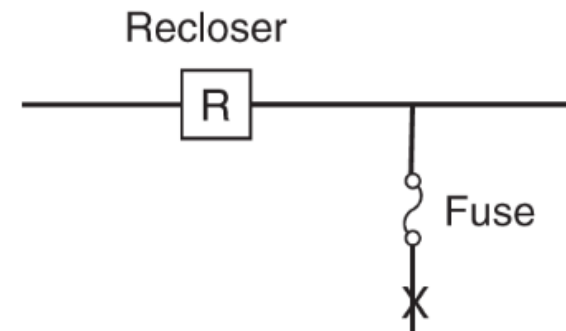

Fig. b: Recloser–fuse locations in a simple distribution feeder system.

7.3 Recloser – Fuse Coordination

- For a permanent fault upstream of the fuse, the recloser should open.
- However, for a temporary fault, none of the devices should stay open.
- For faults downstream of the fuse, the recloser operates on the fast curve first, followed by reclosing and another fast-trip operation.
- If the fault persists, the fast curve of the recloser is disabled, and two additional close and trip operations occur on the slow curve to allow the fuse to clear the fault if it is permanent and downstream of the fuse.

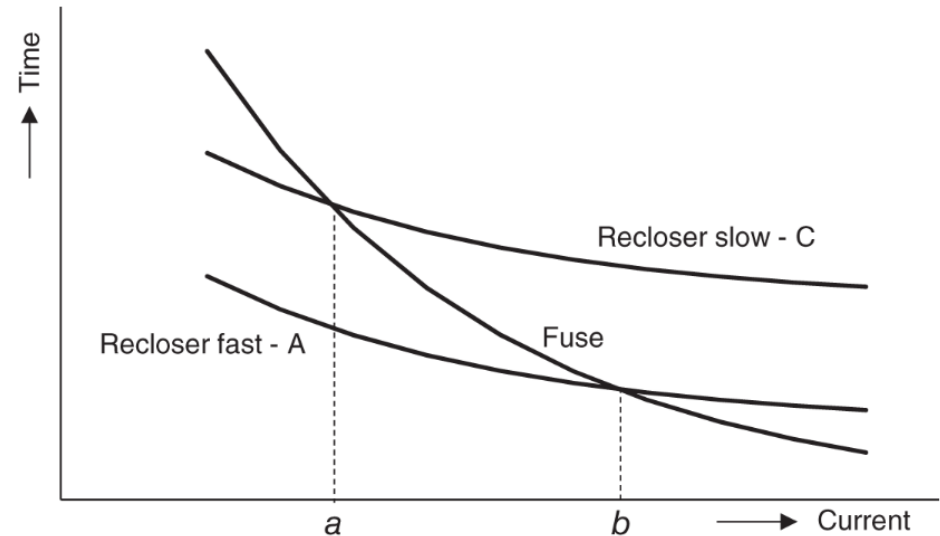

Fig. a: Time–current characteristic curve for a recloser and a downstream fuse link

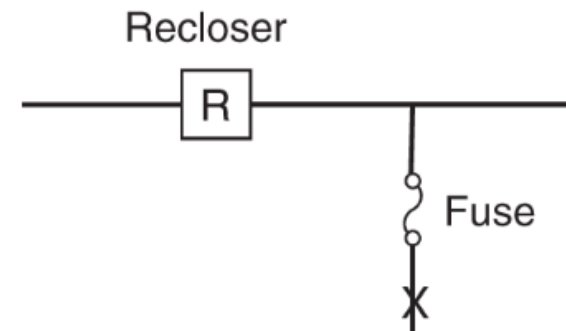

Fig. b: Recloser–fuse locations in a simple distribution feeder system.

7.3 Recloser – Fuse Coordination

- For permanent faults upstream of the fuse, the recloser clears the fault by locking out after operating twice on the slow curve.

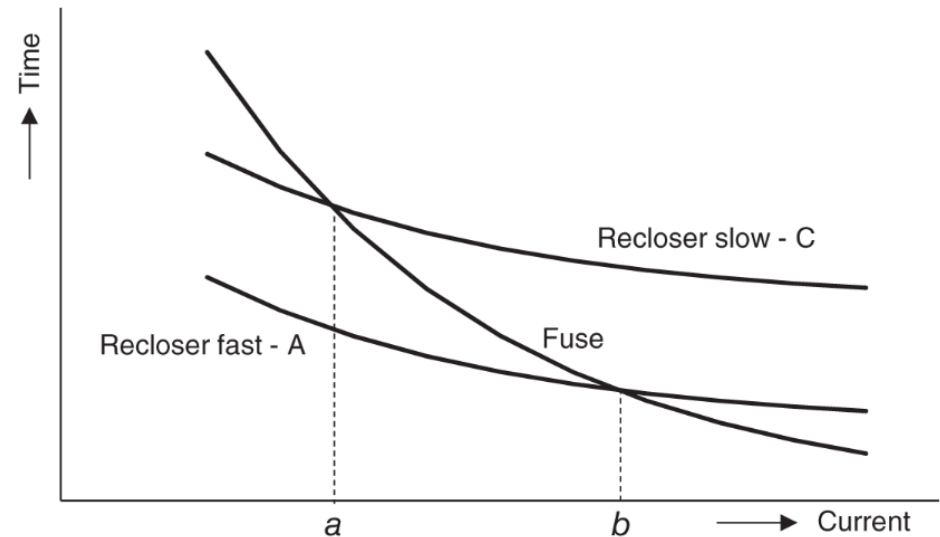

Fig. a: Time–current characteristic curve for a recloser and a downstream fuse link

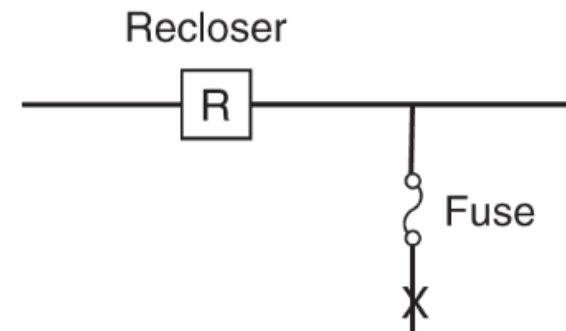

Fig. b: Recloser–fuse locations in a simple distribution feeder system.

57

7.3 Recloser – Fuse Coordination

- Determining values of "a" and "b" is important for coordination between the fuse and the recloser.
- Adjustments are made to account for manufacturing tolerance and cumulative temperature rise in the fuse link during recloser operations.
- The recloser's curves are multiplied by a factor called K-factor.
- A value of 1.35 is typically used for the fast curve of the recloser with an operating sequence of two fast and two slow operations.

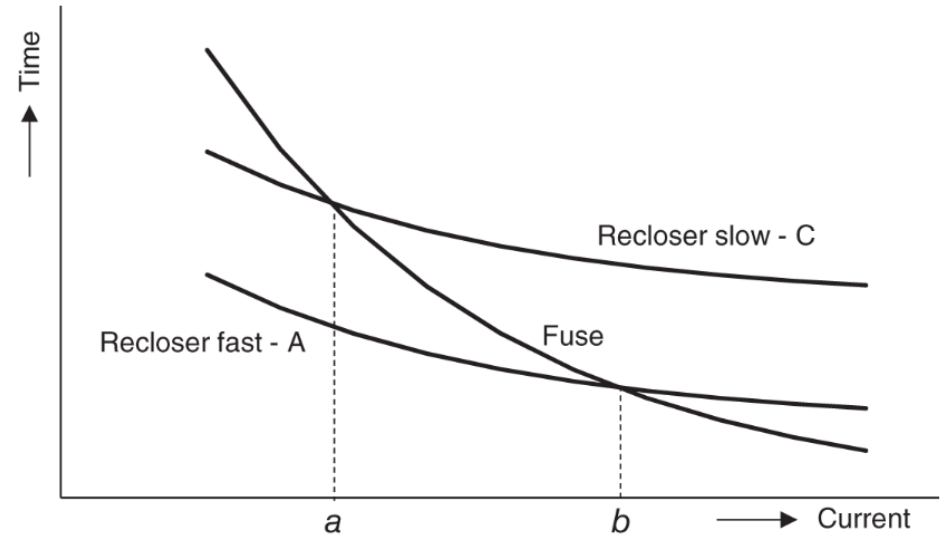

Fig. a: Time–current characteristic curve for a recloser and a downstream fuse link

7.3 Recloser – Fuse Coordination

- For an operating sequence of one fast and three slow operations, the multiplying factor reduces to 1.2 due to lower cumulative temperature rise.
- The intersection of the fuse damaging time curve (75% of minimal-melting-time curve) and the scaled-up fast-trip operation of the recloser gives the value of "b".
- The value of "a" is determined by the intersection of the maximum clearing curve of the fuse with the slow characteristics of the recloser.

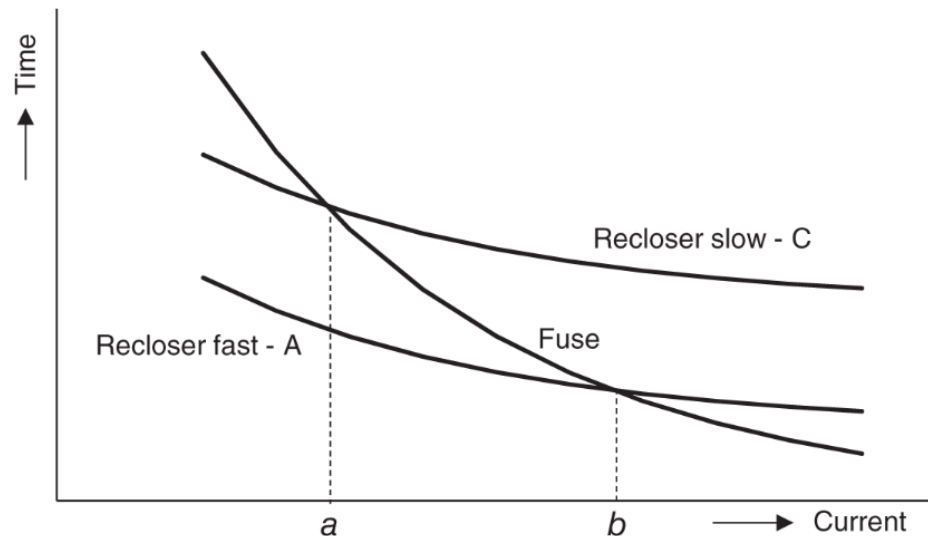

Fig. a: Time–current characteristic curve for a recloser and a downstream fuse link

7.3 Recloser – Fuse Coordination

- If there is a fuse upstream of the recloser, the recloser's slow characteristics must be scaled up using the multiplying factor.
- For the maximum fault at the recloser location, the minimum melting time of the fuse should be higher than the average clearing time of the recloser on the slow curve multiplied by the specified multiplying factor.
- The suggested multiplying factors range from 1.7 to 3.5 and depend on factors such as the recloser type, reclosing time, recloser operating curves, and operating sequence.

| Reclosing time in cycles | Two fast and two delayed sequences | One fast and three delayed sequences | Four delayed sequences |
|--------------------------|------------------------------------|--------------------------------------|------------------------|
| 25 | 2.7 | 3.2 | 3.7 |
| 30 | 2.6 | 3.1 | 3.6 |
| 50 | 2.1 | 2.5 | 2.7 |
| 90 | 1.85 | 2.1 | 2.2 |
| 120 | 1.7 | 1.8 | 1.9 |
| 240 | 1.4 | 1.4 | 1.45 |
| 600 | 1.35 | 1.35 | 1.35 |

- The table provide recommended K-factor values for **coordination with source-side fuse links**.

7.3 Recloser – Fuse Coordination

| Reclosing time in cycles | Two fast operations | One fast operation |
|--------------------------|---------------------|--------------------|
| 25-30 | 1.8 | 1.25 |
| 60 | 1.35 | 1.25 |
| 90 | 1.35 | 1.25 |
| 120 | 1.35 | 1.25 |

- The above table provide Recloser K-factors for **coordination with load-side fuse links**.

7.3 Recloser – Fuse Coordination

- Example:

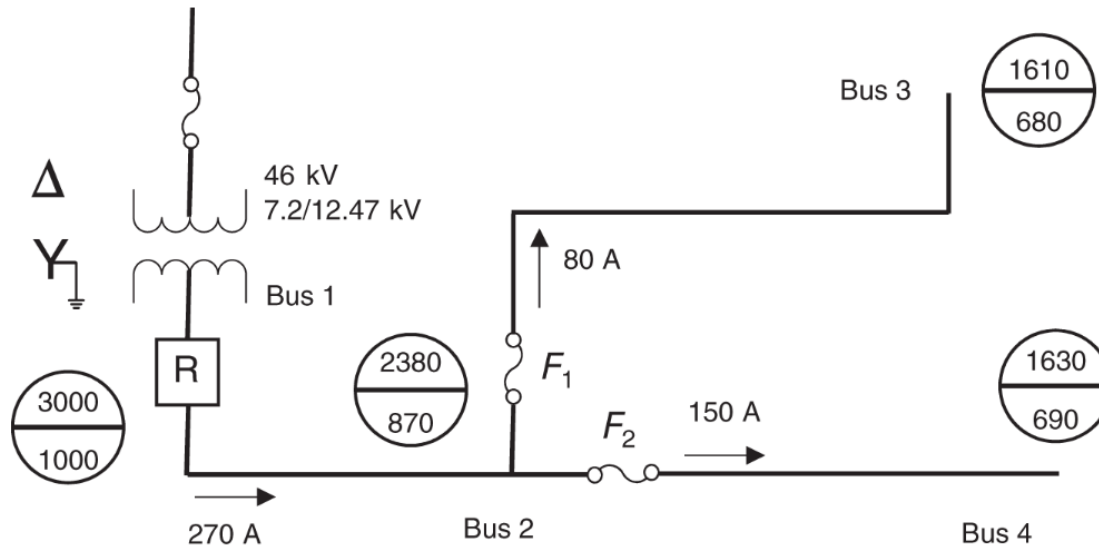

- Consider the system shown in the figure. The objective is to **select recloser settings, fuses F1 and F2**, and the **fuse upstream of the transformer** for the given system. The maximum and the minimum fault currents at distinct locations are shown in circles drawn to the locations. The maximum load currents at distinct locations are shown next to the arrows.

7.3 Recloser – Fuse Coordination

Recloser Selection

Since the maximum load current at Bus 1 is 270 A, it is necessary to choose a set of reclosers with a maximum continuous current rating higher than 270 A.

This is achieved by employing three single-phase reclosers type L with a trip coil rating of 280 A, which have a minimum trip rating of 280 A and interrupting capability of 4000 A.

The interrupting capability is higher than the maximum fault current of 3000 A at Bus 1. Note that this selection limits the ability to increase the maximum load currents in the future without upgrading the reclosers.

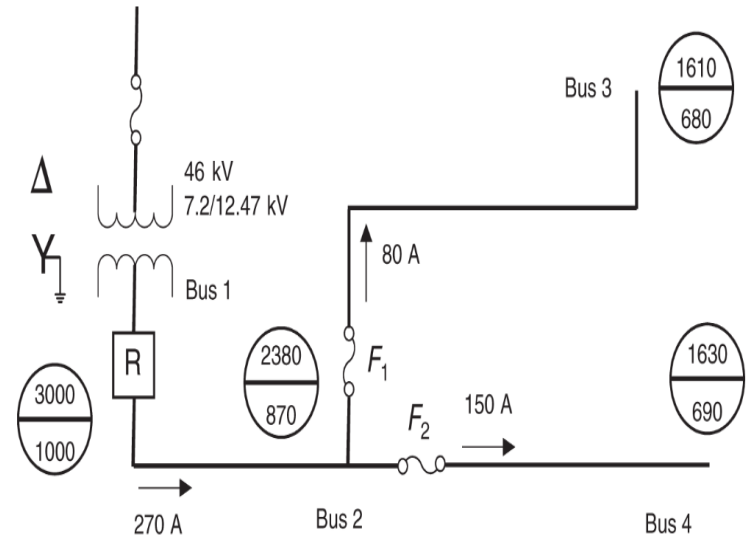

7.3 Recloser – Fuse Coordination

Source-side Fuse and Recloser Coordination

- The source-side fuse needs to be selected so that it does not melt for any fault currents on the load side of the recloser.
- It means that for the maximum fault current seen by the recloser (3000 A), the minimum melting time of the fuse must be greater than the clearing time of the recloser's delayed curve.
- Some other factors as discussed below must be considered to select this fuse.

Transformer Turns Ratio

- Since the source-side fuse is on the primary side of the transformer, the turns ratio of the transformer needs to be considered because currents from the low-voltage side have a smaller magnitude when seen from the high-voltage side since power across the transformer must be equal. Given that the transformer turns ratio is $N = 3.7$, the fuse time–current curves across the transformer have the following multiplying factors due to Δ -Y connection of the transformer:
 - Three-phase fault: $N = 3.7$
 - Phase-to-phase fault: $0.87 * N = 3.2$
 - Phase-to-ground fault: $1.73 * N = 6.4$
- The phase-to-phase fault current has the lowest multiplying factor, and it is used as the limiting factor for the source-side fuse and recloser coordination because it results in the tightest requirement.

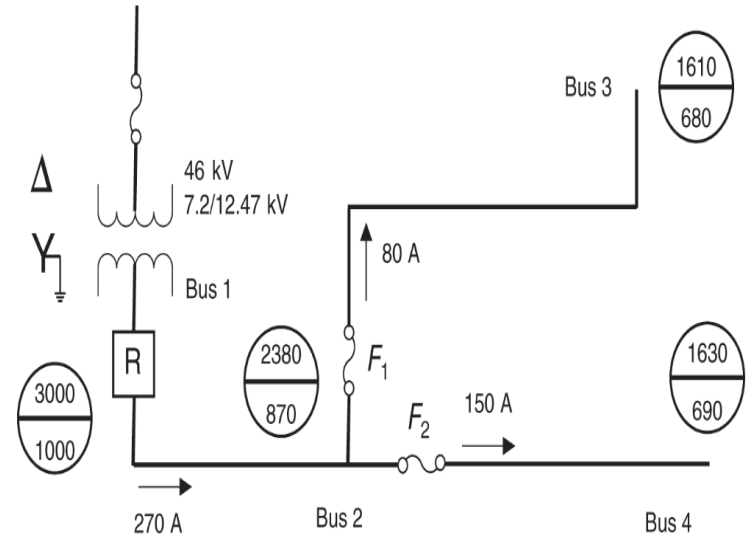

7.3 Recloser – Fuse Coordination

Continuous Load Current

- The source-side fuse also needs to consider the normal operating conditions, that is the continuous peak load current.
- In this case, the maximum continuous load current is 270 A on the low side of the transformer, which corresponds to 73 A of current on the high side of the transformer.
- Generally, fuses start operating at currents that are greater than two times their rating. Thus, they can easily carry currents up to 1.5 times their rating. For instance, a 65E fuse link can carry up to 97.5 A of continuous current, and thus, it is suitable. For this example, we select a 46-kV 65E slow fuse link.

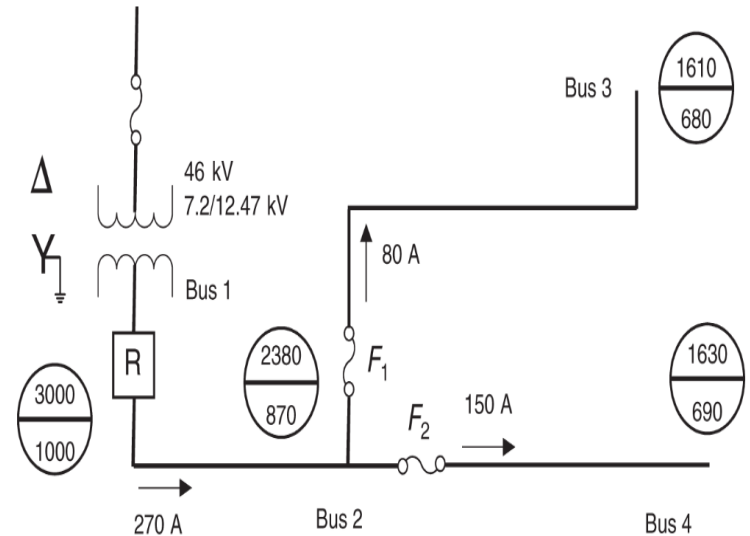

7.3 Recloser – Fuse Coordination

Recloser K-factor

- The K-factor value for the recloser is found according to the type of the recloser sequence and the reclosing intervals. For the recloser sequence of two fast operations followed by two delay operations, a K-factor of 1.7 is used to scale the recloser's slow characteristics.

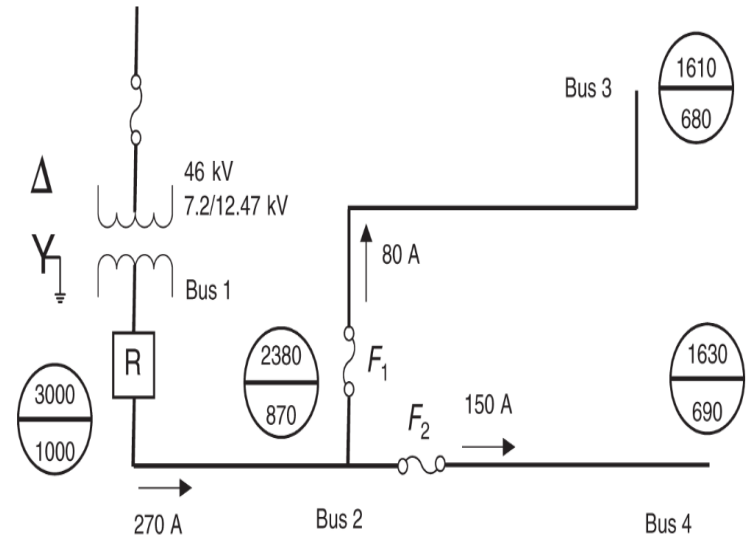

7.3 Recloser – Fuse Coordination

Selection

- The Figure on the right shows the original and scaled versions of the fuse link and recloser curves.
- The operating time of the recloser's slow curve is multiplied by the K-factor, and the current is scaled by a factor of 3.2 for the fuse link curve.
- The intersection of the MMC for a fuse link type 65ES and the modified C curve for the recloser is found at approximately 1800 A.
- A different fuse link is needed to ensure proper coordination at a fault current of 3000 A, with a gap between the MMC of the fuse link and the recloser operating time on the modified curve larger than 0.5 seconds.

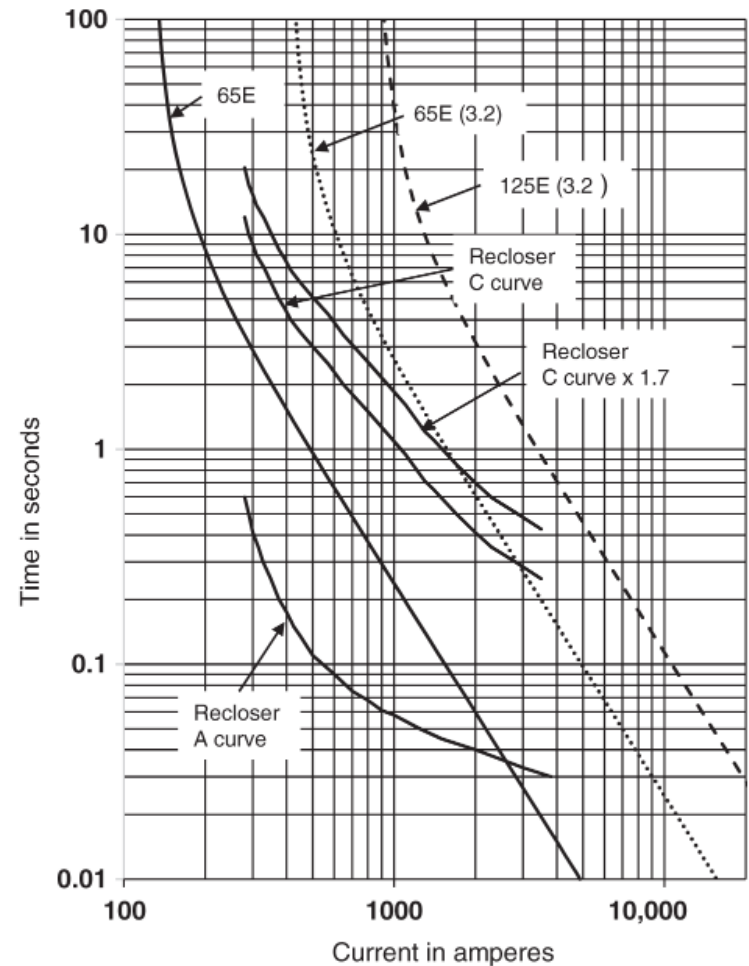

Fig. Operating time of L-type recloser and E-type slow upstream fuse links.

7.3 Recloser – Fuse Coordination

Selection

- The operating time of the recloser on the modified curve is 0.5 seconds at 3000 A.
- A fuse link with a melt time greater than 1 second (0.5 seconds + 0.5 seconds) is required for proper coordination.
- The scaled MMC of slow 125E fuse link has a melt time slightly higher than one second for 3000 A.
- Fuse links higher than 125E will comply with the coordination requirement.
- Therefore, a 125E slow fuse link is chosen.

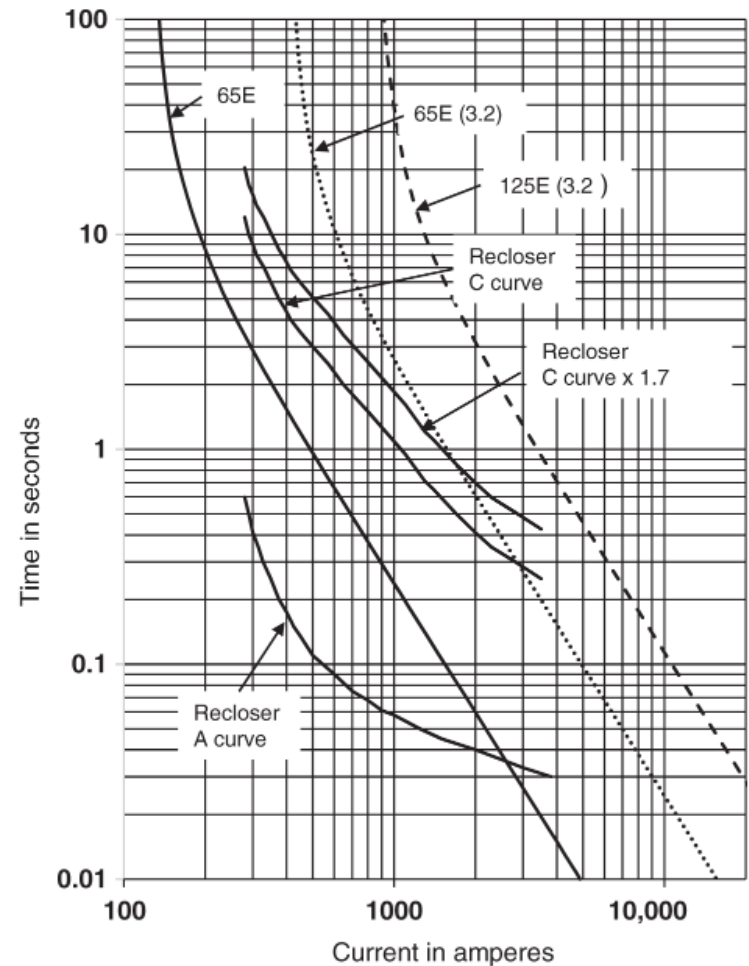

Fig. Operating time of L-type recloser and E-type slow upstream fuse links.

7.3 Recloser – Fuse Coordination

Load-side Fuse and Recloser Coordination

- Coordination between fuses F1 and F2 and the recloser needs to be set up so that:
- In the event of a temporary fault between buses 2 and 3 or 4, neither F1 nor F2 burns out before the recloser's fast operation clears the fault.
- In the event of a permanent fault, fuses F1 and F2 clear the fault by melting before the recloser's delay operation happens.

7.3 Recloser – Fuse Coordination

| Reclosing time in cycles | Two fast operations | One fast operation |
|--------------------------|---------------------|--------------------|
| 25–30 | 1.8 | 1.25 |
| 60 | 1.35 | 1.25 |
| 90 | 1.35 | 1.25 |
| 120 | 1.35 | 1.25 |

Table: Recloser K-factors for coordination with load-side fuse links.

Continuous Load Current

- Since the recloser has already been selected, it is necessary to choose appropriate fuse links to achieve proper coordination.
- Considering the maximum continuous load currents, it is possible to find the minimum ratings of fuse links for F_1 and F_2 .
- The load currents for F_1 and F_2 are 80 and 150 A, respectively. This means that for F_1 it is necessary to choose a rating of 65T or higher ($80/1.5 = 53.333$ A), and for F_2 it is necessary to choose 100T or higher ($150/1.5 = 100$ A).
- Like the slow curve, a K-factor must be applied to the recloser fast curve. The K-factor value of 1.35 can be found from the Table.

7.3 Recloser – Fuse Coordination

Minimum Melt Time (MMT)

- The MMT of each of the fuses needs to be higher than the adjusted fast operation (curve A times 1.35) of the recloser between the minimum fault current (680 A for F1 and 690 A for F2) and the maximum fault current seen by the fuses (2380 A). This means that:
- F1 and F2 MMT should be higher than 0.05 seconds for a current of 2380 A. Figure 11.24 shows the A curve of the recloser times 1.35 and MMCs of 65T, 80T, and 100T fuse links. Both 80T and 100T meet the requirement, but 65T does not.
- Figure shows the A curve of the recloser times 1.35 and MMCs of 65T, 80T, and 100T fuse links. Both 80T and 100T meet the requirement, but 65T does not.
- F1 and F2 MMT should be higher than 0.1 seconds for currents of 680 and 690 A. All the fuse links meet the requirement.

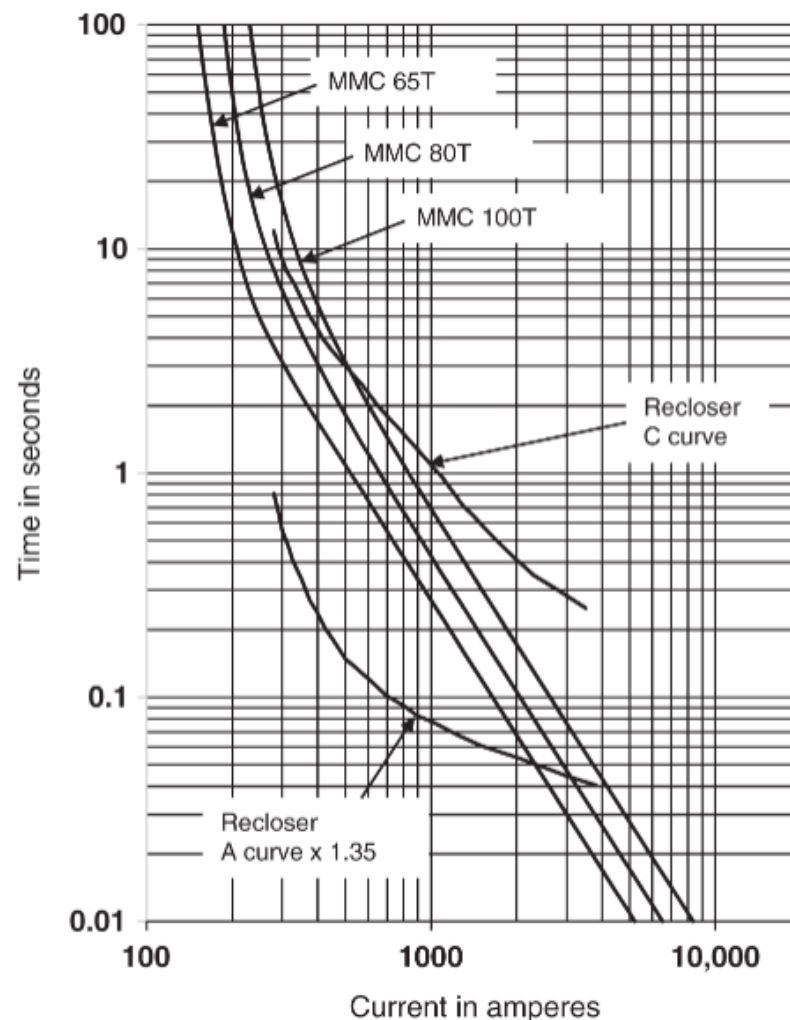

Fig: Adjusted fast curve (Curve A) of recloser and MMC of selected fuse links

7.3 Recloser – Fuse Coordination

Maximum Clearing Time (MCT)

The maximum clearing time (MCT) of the fuses must be lower than the delayed operation (curve C) of the recloser for the maximum and minimum currents seen by the fuses. This means that:

- F1 and F2 MCT should be lower than 0.37 seconds approximately for a current of 2380 A. Figure 11.25 shows the C curve of the recloser and TCC of 65T, 80T, and 100T fuse links. All the fuse links meet the requirement.
- F1 and F2 MCT should be lower than 1.8 seconds approximately for currents of 680 and 690 A, respectively. Both 65T and 80T meet the requirement, but 100T does not.

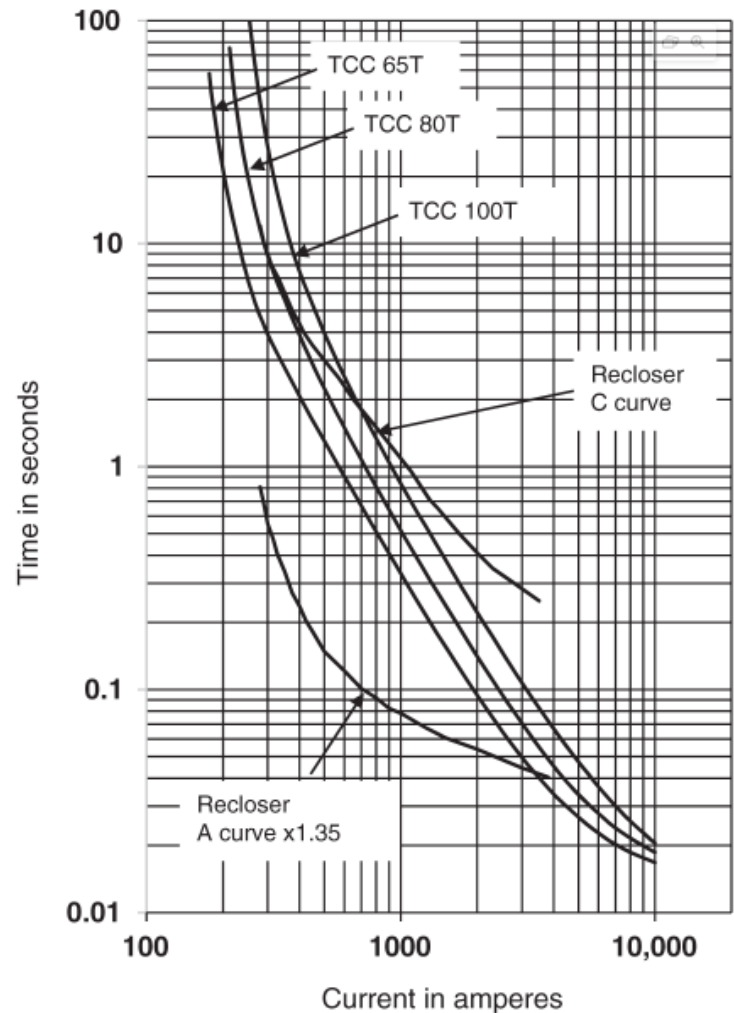

Fig: Slow curve (Curve C) of recloser and TCC of selected fuse links.

7.3 Recloser – Fuse Coordination

Selection

- The analysis indicates that the only fuse that satisfies all the requirements is the 80T fuse.
- Although the desired fuse for F1 was 65T, it needs to be increased to 80T to ensure adequate protection.
- Similarly, the desired fuse for F2 was 100T, but it needs to be reduced to 80T for proper coordination with the recloser.
- It's important to note that the 80T fuse will coordinate with the recloser, but it may melt under maximum loading conditions.

7.4 Recloser – Sectionalizer Coordination

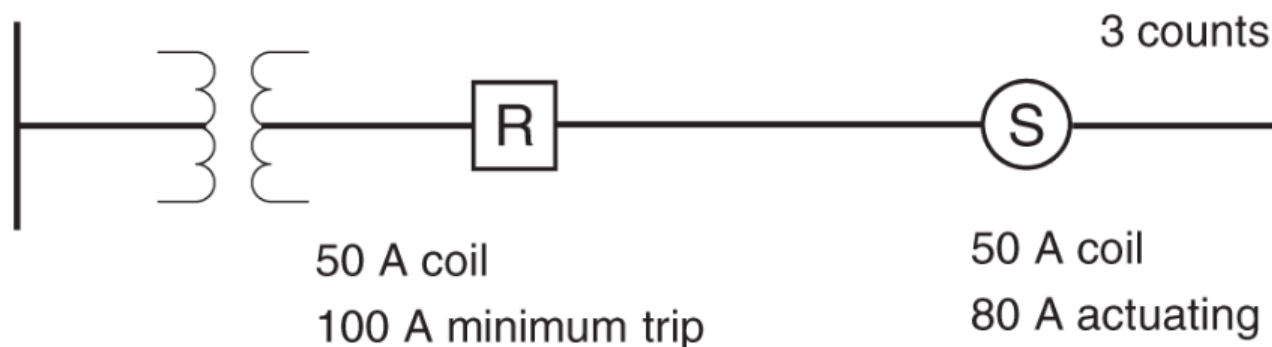

Fig: Basic sectionalizer–recloser coordination

- The sectionalizer is set for one less operational count than the immediate recloser on the source side as shown in the figure.
- In this case, if the recloser is set for four operations, the sectionalizer should be set for three operations.
- The continuous current rating of both the devices should be the same.
- The actuating current of the sectionalizer is set to 80% of the recloser's minimum trip rating.

7.5 Circuit Breaker – Recloser Coordination

Models for Relay – Controlled Circuit Breakers

- The overcurrent relay-controlled circuit breakers have a time delay unit with characteristics similar to that shown in Figure, and an instantaneous unit.
- The relay characteristics, its pickup value, and TD are selected based on the given load and fault currents. The relay type CO-8 is used often.

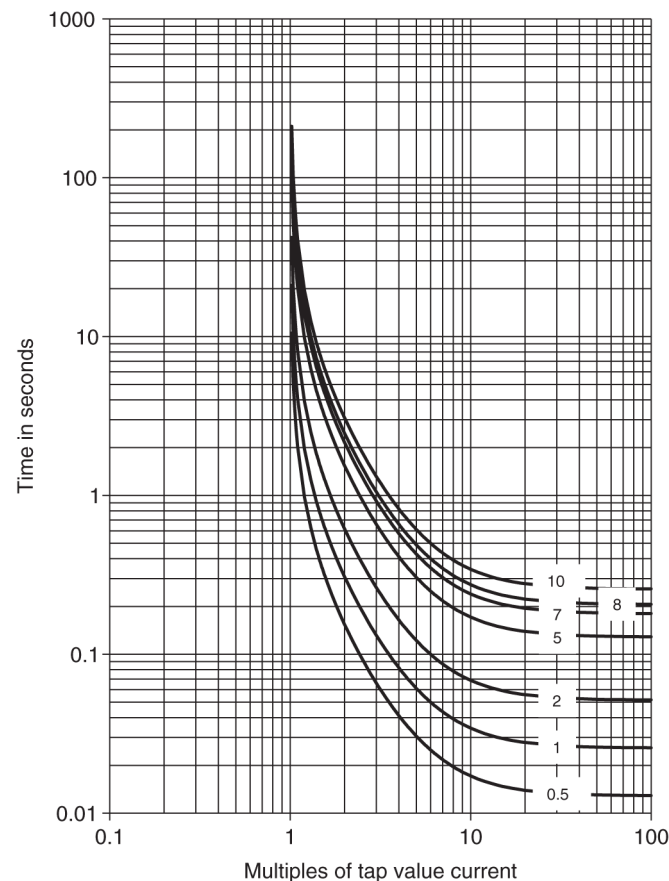

Fig: Time–current characteristics of CO-8 time-inverse overcurrent relay at different time dial values.

7.5 Circuit Breaker – Recloser Coordination

Rules for Coordination

- The relay time-current characteristics of the circuit breaker should be set above the characteristics of the primary device.
- The pickup and time-dial settings of the relay should provide sufficient safety margin with the selected characteristics of the recloser or other devices.
- The instantaneous relay characteristics should have a proper safety margin above the fast curves of the recloser or other devices.
- The time delay characteristics of the relay should allow the slow curves of the recloser to act first.
- Static overcurrent relays are easier to coordinate with reclosers as they do not have issues of overtravel and coasting.
- If mechanical relays are used, appropriate margins must be included to ensure proper coordination.

7.5 Circuit Breaker – Recloser Coordination

Example:

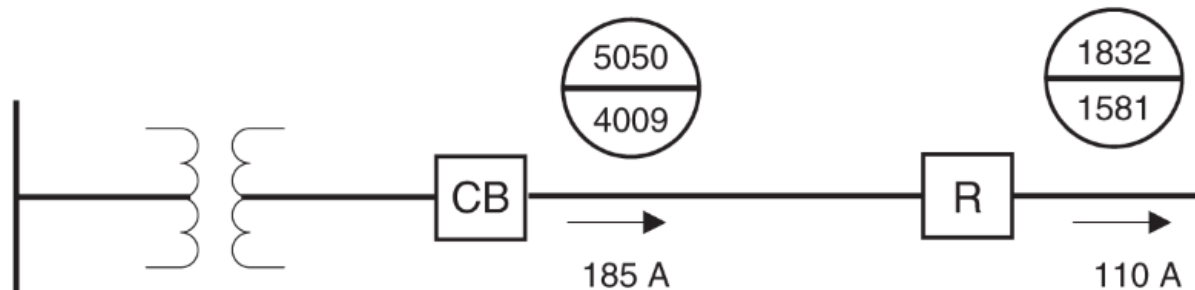

Fig: Main feeder of a distribution system.

- Figure shows an example of a distribution feeder protected by a recloser and a circuit breaker along with the minimum and maximum faults. Find settings of the relay for the CB to coordinate with the recloser.

7.5 Circuit Breaker – Recloser Coordination

Solution:

- The first step is to select a recloser. Since the full load current is 110 A, a recloser with 140 A trip coil setting is appropriate.
- Figure shows the recloser curves. We select a CO-8 relay for the circuit breaker.
- For a load current of 185 A, 200 : 5 CT will work.
- Further, we select 5 A as the TS for the CO-8 relay. This will allow some margin for overload on the feeder.

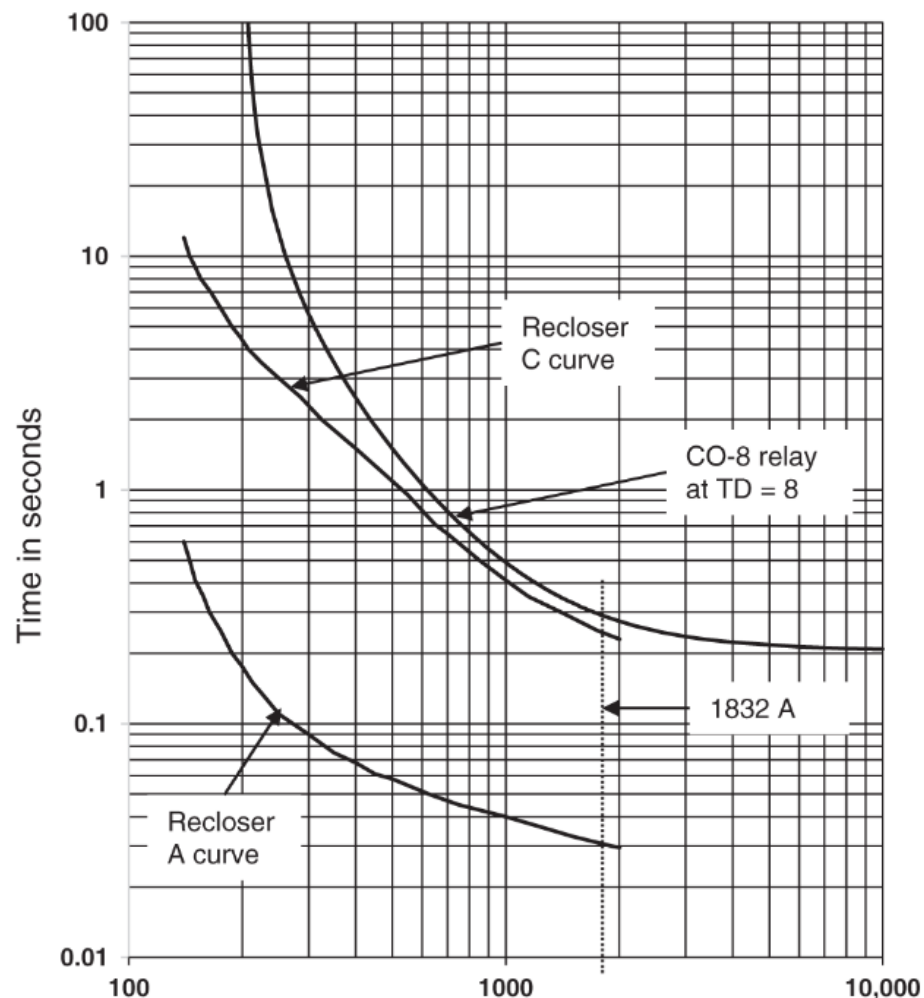

Fig. Recloser and CO-8 relay-operating curves.

7.5 Circuit Breaker – Recloser Coordination

Solution:

- Now, we have to select the TD setting for the relay to coordinate with the recloser. At 1832 A, which is the largest fault current seen by both the recloser and the circuit breaker, the recloser takes 0.24 seconds to operate on the slow curve (curve C).
- We want the relay to take higher time than that at the same current. We compute the MTS for this current, which is:

$$\begin{aligned} \text{MTS} &= \frac{I_{\text{fault}}}{(\text{CT Ratio})(\text{Tap Setting})} \\ &= \frac{1832}{\left(\frac{200}{5}\right)(5)} = 9.16 \end{aligned}$$

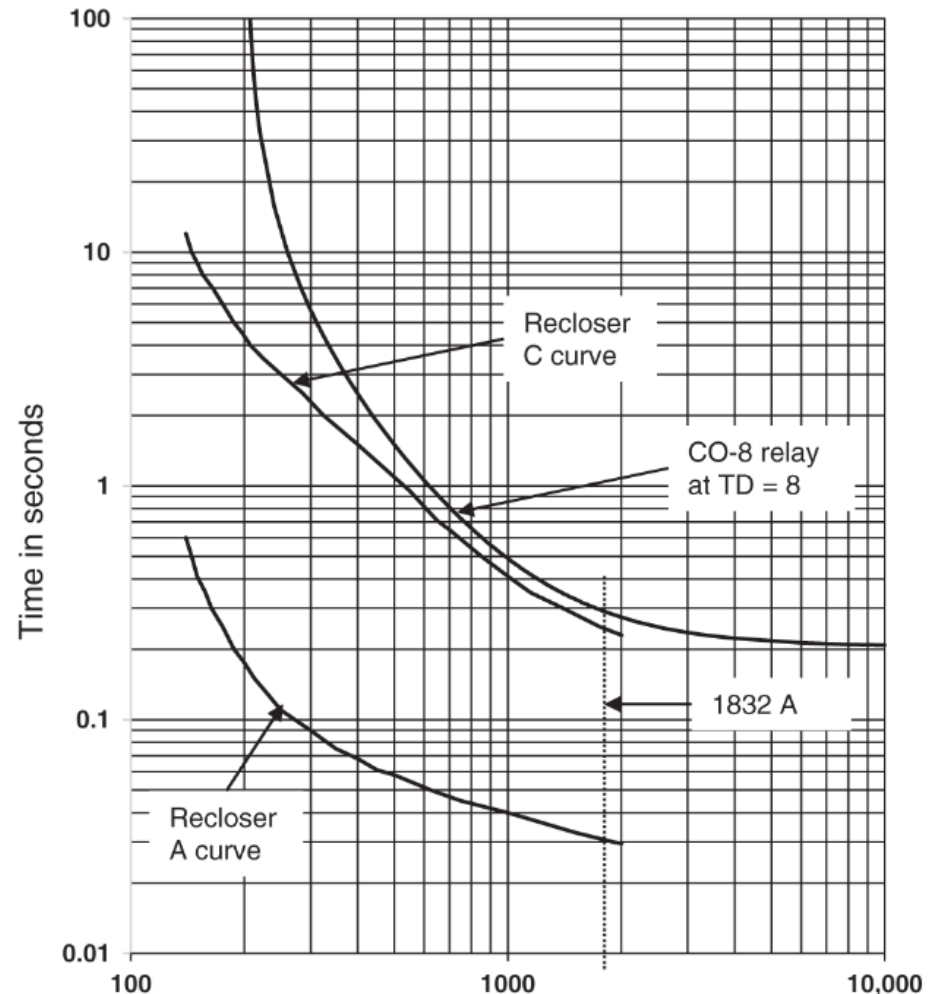

Fig. Recloser and CO-8 relay-operating curves.

7.5 Circuit Breaker – Recloser Coordination

Solution:

- CO-8 relay with TD of 8 takes 0.3 seconds to operate, which provides sufficient margin between the operating time of the recloser and the circuit breaker.

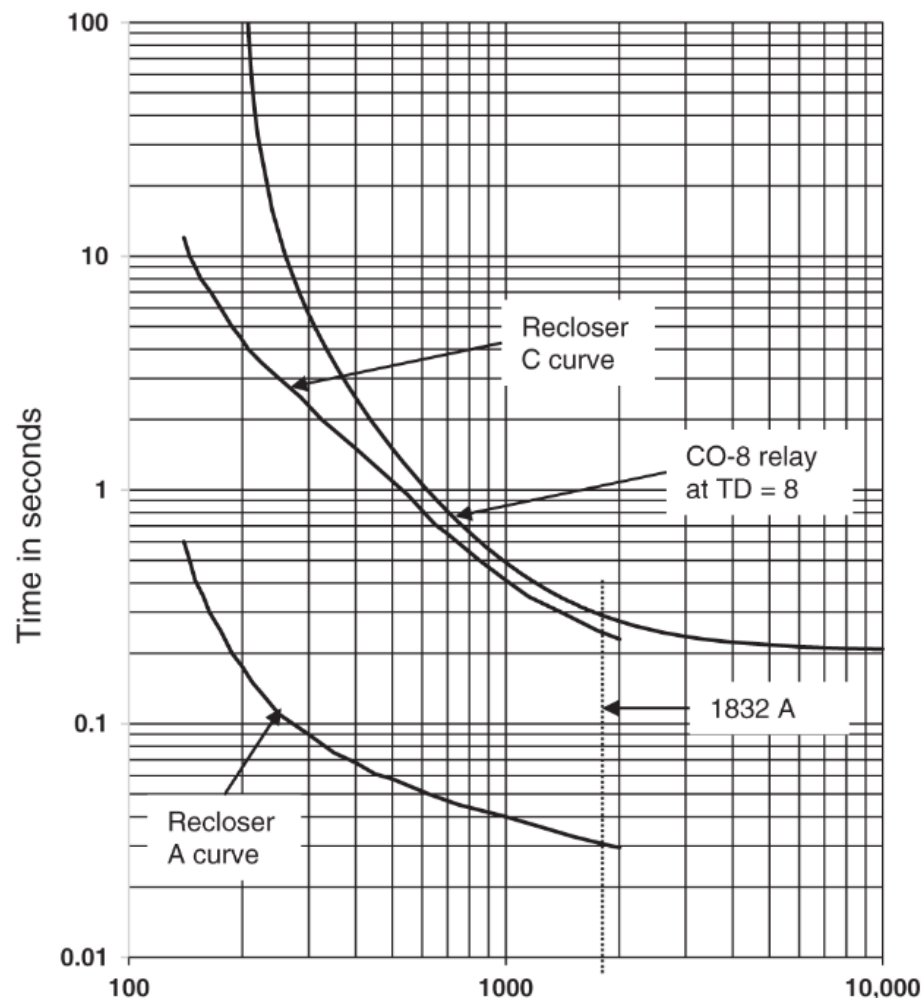

Fig. Recloser and CO-8 relay-operating curves.

8. New Digital Sensing and Measuring Devices

8.1 Phasor Measurement Units (PMUs)

- Synchrophasors are time-synchronized numerical values that represent both the magnitude and phase angle of the sine waves in AC electricity.
- They provide accurate measurements of grid conditions and are obtained using high-speed monitors called phasor measurement units (PMUs).
- PMUs are significantly faster than supervisory control and data acquisition (SCADA) systems, operating at a rate 100 times faster.
- Synchrophasor technology enables real-time monitoring of grid conditions and offers insights into grid stability and stress.
- PMU measurements are highly accurate and provide valuable data for improving grid reliability, efficiency, and reducing operating costs.
- The use of synchrophasors allows for real-time operations and offline engineering analyses to optimize grid performance.

8. New Digital Sensing and Measuring Devices

8.1 Phasor Measurement Units (PMUs)



Fig: Phasor Measurement Unit

8. New Digital Sensing and Measuring Devices

8.2 Microphasor Measurement Units

- PMUs installed on the power grid are currently positioned on the transmission system or in substations.
- μ PMUs create real-time synchrophasor data from the consumer voltage level, offering new insights into modern power systems.
- μ PMUs are more cost-effective to create compared to current commercial PMUs.
- The affordability of μ PMUs allows for deploying a larger number of units, providing higher resolution monitoring of the distribution grid.
- The visibility provided by μ PMUs opens up new applications for postmortem event analysis, identification, and near real-time monitoring.
- One such application is fault location on distribution systems or microgrids, where μ PMUs offer accurate results.

8. New Digital Sensing and Measuring Devices

8.2 Micro-phasor Measurement Units



Fig: Micro-phasor measurement unit

8. New Digital Sensing and Measuring Devices

8.3 Optical Line Current Sensors

- Optical Line Current Sensors are directly hung from an overhead line to obtain direct, digital current signals in each phase.
- These pole-top units utilize the Faraday effect to achieve accurate and precise current measurements of line currents.
- For a three-phase system, three sensors are required.
- Pole-top units can be used for overhead lines ranging from 120 V up to 34.5 kV levels.
- They can also enable power quality measurements through a power quality (PQ) meter.
- There is a possibility of adopting these units for underground systems in the future.

8. New Digital Sensing and Measuring Devices

8.4 Optical Voltage Sensors

- These units utilize the Pockels effect to derive voltage signals.
- Similar to the current sensors, three sensors are required to obtain digital and accurate voltage values from each of the three phases.
- Initially, these sensors are used for obtaining voltage values in overhead lines.
- In the future, they can also be applied to underground distribution systems for voltage measurement purposes.

8. New Digital Sensing and Measuring Devices

8.5 Digital Pressure and Temperature Sensors

- Research and development work is currently underway to develop these newer sensors.
- Utilities and equipment manufacturers are actively involved in the development process.
- These sensors are not yet common in the industry.
- However, with ongoing efforts, it is expected that they will become a reality in the near future.

8. New Digital Sensing and Measuring Devices

8.5 Evolving Sensors

- Other developing state-of-the-art-sensors such as extremely high-frequency point on wave, dynamic high-range sensors, optical PMU, and MagSense should be considered for adoption as time passes on.
- As nanotechnology matures, it is possible to envisage the development of newer sensors such as nanosensors for all sensing and measurement of electrical and nonelectrical quantities in the smart grid system.
- One could even expect genetic sensors such as bacterial nanobionics sensors to penetrate the future distribution systems to improve the speed, precision, and accuracy of the above mentioned electrical variables.

9. Emerging Protection System Design and Coordination

- Conventional protection approaches for distribution systems may become obsolete due to changes in the system.
- Increased deployment of distributed energy resources (DER) in distribution systems has led to changes in the system topology.
- Inverter-based resources (IBRs) pose challenges for fault detection and protection coordination.
- Current-limiting features of inverters make it difficult to detect faults.
- Flow of current from distributed resources towards the fault further complicates protection.
- Future protection schemes may rely on advanced methodologies and communication between system components.
- Local and global coordination can be achieved using effective computer communication systems.
- This approach is applicable to systems of any size, including grids and microgrids.
- It can be used for both planning and automation of distribution systems.

Thank You!